

UNITED STATES PATENT AND TRADEMARK OFFICE

---

BEFORE THE PATENT TRIAL AND APPEAL BOARD

---

UNIFIED PATENTS, INC.  
Petitioner

v.

CLOUDING IP, LLC  
Patent Owner

---

Case IPR2013-00586  
Patent 6,738,799 B2

---

Before JAMESON LEE, JUSTIN BUSCH, and RAMA G. ELLURU,  
*Administrative Patent Judges.*

BUSCH, *Administrative Patent Judge.*

DECISION  
Institution of *Inter Partes* Review  
*37 C.F.R. § 42.108*

## I. INTRODUCTION

### A. Background

On September 16, 2013, Unified Patents, Inc. (“Unified”) filed a Petition to institute an *inter partes* review of claims 1, 5-10, 12, 16-21, 23, 24, 30, 31, 37, and 42 (the “challenged claims”) of U.S. Patent No. 6,738,799 B2 (Ex. 1001, “the ’799 Patent”) pursuant to 35 U.S.C. §§ 311-319. Paper 1 (“Pet.”). In response, Clouding IP, LLC (“Clouding”) filed a Patent Owner Preliminary Response. Paper 5 (“Prelim. Resp.”). We have jurisdiction under 35 U.S.C. § 314.

The standard for instituting an *inter partes* review is set forth in 35 U.S.C. § 314(a), which provides as follows:

THRESHOLD – The Director may not authorize an *inter partes* review to be instituted unless the Director determines that the information presented in the petition filed under section 311 and any response filed under section 313 shows that there is a reasonable likelihood that the petitioner would prevail with respect to at least 1 of the claims challenged in the petition.

The information presented in the Petition sets forth Unified’s contentions of unpatentability of the challenged claims under 35 U.S.C. §§ 102 and 103 based on the following specific grounds (Pet. 16-57):

Reference[s]	Basis	Claims challenged
Williams <sup>1</sup>	§ 102(e)	1, 12, 23, 24, 30, 31, 37, and 42
Williams and Miller <sup>2</sup>	§ 103(a)	5-10 and 16-21

---

<sup>1</sup> U.S. Patent No. 5,990,810, issued Nov. 23, 1999 (Ex. 1006) (“Williams”).

<sup>2</sup> U.S. Patent No. 5,832,520, issued Nov. 3, 1998 (Ex. 1004) (“Miller”).

Reference[s]	Basis	Claims challenged
Balcha <sup>3</sup>	§ 102(e)	37 and 42
Balcha and Miller	§ 103(a)	1, 5, 9, 10, 12, 16, 20, 21, 23, 24, 30, and 31
Balcha, Miller, and Freivald <sup>4</sup>	§ 103(a)	6-8 and 17-19
Balcha and Freivald	§ 103(a)	1, 12, 23, 30, 37, and 42

Upon consideration of the Petition and Patent Owner Preliminary Response, for the reasons described below, we determine that Unified has demonstrated a reasonable likelihood of prevailing on at least one ground on each of the challenged claims. Accordingly, pursuant to 35 U.S.C. § 314, we grant the Petition and institute *inter partes* review as to claims 1, 5-10, 12, 16-21, 23, 24, 30, 31, 37, and 42 of the '799 Patent.

*B. Related Proceedings*

Unified indicates that the '799 Patent was the subject of the following terminated *inter partes* reviews before the Board: Oracle Corp. v. Clouding IP, LLC, IPR2013-00073<sup>5</sup> and Oracle Corp. v. Clouding IP, LLC, IPR2013-00261. Pet. 4. Unified indicates that the '799 Patent is the subject of the following co-pending federal district court cases: *Clouding IP, LLC v. EMC Corp., et al.*, Case No. 1:13-cv-01455 (D. Del.); *Clouding IP, LLC v. Dropbox Inc.*, Case No. 1:13-cv-01454 (D. Del.); *Clouding IP, LLC v. SAP AG, et al.*, Case No. 1:13-cv-01456 (D. Del.); *Clouding IP, LLC v. Verizon Inc.*, Case No. 1:13-cv-01458 (D. Del.); *Clouding IP, LLC v. Rackspace,*

---

3 U.S. Patent No. 6,233,589 B1, issued May 15, 2001 (Ex. 1003) (“Balcha”).

4 U.S. Patent No. 5,898,836, issued Apr. 27, 1999 (Ex. 1005) (“Freivald”).

5 Unified identifies IPR2012-0073 as a related matter. Pet. 4. However, IPR2013-00073 is the related *inter partes* review involving the '799 Patent.

*Hosting Inc.*, Case No. 1:12-cv-00675 (D. Del.); *Clouding IP, LLC v. Amazon.com Inc.*, Case No. 1:12-cv-00641 (D. Del.); *Clouding IP, LLC v. Oracle Corp.*, Case No. 1:12-cv-00642 (D. Del.); *Clouding IP, LLC v. Google Inc.*, Case No. 1:12-cv-00639 (D. Del.). Pet. 4. Unified indicates that the '799 Patent also was the subject of the following terminated federal district court cases: *Clouding IP, LLC v. Apple Inc.*, Case No. 1:12-cv-00638 (D. Del.); and *Clouding IP, LLC v. Microsoft Corp.*, Case No. 1:12-cv-00640 (D. Del.). Pet. 4.

*C. Real Party-in-Interest*

Clouding alleges that Google, Inc. (“Google”) is an unidentified real party-in-interest and that Google was served with a complaint alleging infringement of the '799 Patent on May 24, 2012, more than one year before the Petition was filed. Prelim. Resp. 12-20. Clouding argues against institution because the Petition fails to identify all real parties-in-interest as required by 35 U.S.C. § 312(a)(2) and because the Petition is barred under 35 U.S.C. § 315(b). *Id.*

A petition for *inter partes* review may be considered only if, among other requirements, the petition identifies all real parties-in-interest. 35 U.S.C. § 312(a)(2); *see also* 37 C.F.R. § 42.8(b). In addition, an *inter partes* review may not be instituted if the petition is filed more than one year after the date on which a real party-in-interest is served with a complaint alleging infringement of the patent. 35 U.S.C. § 315(b). “Whether a party who is not a named participant in a given proceeding nonetheless constitutes a ‘real party-in-interest’ or ‘privy’ to that proceeding is a highly fact-dependent question.” Office Patent Trial Practice Guide, 77 Fed. Reg. 48,756, 48,759 (Aug. 14, 2012) (citation omitted). The Office Patent Trial

Practice Guide provides guidance regarding factors to consider in determining whether a party is a real party-in-interest. Considerations may include whether a non-party exercises control over a petitioner's participation in the proceeding or whether a non-party is funding the proceeding or directing the proceedings. 77 Fed. Reg. at 48,759-60.

Clouding notes that Google is a founding principal of Unified.

Prelim. Resp. 13. Clouding further states:

Petitioner accepts money from others who pay Petitioner for filing *inter partes* review petitions in which Petitioner names itself as the sole real party in interest. The payments are the *quid pro quo* in exchange for the filing of the petitions and the scheme is intended to allow the true entity concerned about the underlying patent to avoid the estoppel effects of *inter partes* review should the patent survive.

Prelim. Resp. 13-14. On the basis of the foregoing, Clouding alleges that Google is a real party-in-interest. *Id.* However, Clouding's proffered evidence (*see* Prelim. Resp. 13-19) does not support those allegations. Clouding points to an article posted on Bloomberg L.P.'s website (Ex. 2001, 3), which states that Google "started Unified Patents" and an article posted on Unified's website (Ex. 2005, 1), which states that Google was a "[f]ounding member" of Unified. Clouding also refers to another article on Unified's website, which states that Unified "counters the risk and cost of patent troll litigation by protecting strategic technologies" (Ex. 2003, 2), but that does not show that Unified's members are charged in exchange for filing *inter parte* reviews. Clouding's proffered evidence does not demonstrate persuasively that Google is a principal of Unified, that Google has any control over the instant proceeding, or that Google is funding the instant proceeding. Therefore, Clouding fails to demonstrate

that Google is a real party-in-interest for the purposes of § 312(a)(2) and § 315(b).

Because Clouding fails to demonstrate sufficiently that Google is a real party-in-interest, Clouding has not established that the Petition does not identify all real parties-in-interest for this proceeding as required by § 312(a)(2). Furthermore, in failing to establish that Google is a real party-in-interest, Clouding also has failed to demonstrate that the Petition is barred under § 315(b) on the ground that the Petition was filed more than one year after Google was served with a complaint alleging infringement of the '799 Patent.

*D. The '799 Patent*

The '799 Patent is related to a method for file synchronization using a signature list. Ex. 1001, Title. In particular, the '799 Patent discloses a method for synchronizing the local copies of files on client computers to the current versions of the files on a network drive. Ex. 1001, 1:24-27. According to the '799 Patent, an object of the method is to provide a mechanism by which a user can be provided automatically with a current version of a subscription file in an efficient manner. Ex. 1001, 3:36-41. This is accomplished by having a server computer monitor network files for changes, and then send users email notifications and updates when there is a change to the files. Ex. 1001, 3:41-44.

Of the challenged claims, claims 1, 12, 23, 30, 37, and 42 are independent claims.

Claims 1 and 37 are exemplary of the claimed subject matter of the '799 Patent, and are reproduced as follows (emphasis added):

1. A method for a first computer to generate an update for transmission to a second computer that permits the second computer to generate a copy of a current version of a file comprised of a first plurality of file segments from a copy of an earlier version of the file comprised of a second plurality of file segments, such that each file segment corresponds to a portion of its respective file, the method comprising the steps of:

for each segment of the current version of the file,

(a) searching an earlier version of a signature list corresponding to an earlier version of the file for an old segment signature which matches a new segment signature corresponding to the segment;

(b) if step (a) results in a match, writing *a command* in the update for the second computer *to copy* an old segment of the second computer's copy of the earlier version of the file into the second computer's copy of the current version of the file, wherein the old segment corresponds to the segment for which a match was detected in step (a); and

(c) if step (a) results in no match, writing *a command* in the update for the second computer *to insert* a new segment of the current version of the file into the second computer's copy of the current version of the file;

wherein the new segment of the current version of the file is written into the update and the unchanged segment is excluded from the update; and

wherein steps (a) through (c) are performed by the first computer, without interaction with the second computer, in response to the first computer detecting a change between the current version of the file and the earlier version of the file.

37. A method for a first computer to provide updates for transmission to a second computer that permits the second computer to obtain most recent versions of files, the method

comprising the steps of:

(a) determining whether the second computer has *a latest version* of a file, wherein said determining is performed by the first computer without interaction with the second computer;

(b) generating an update, if the second computer does not have a latest version of the file, wherein said generating is performed by the first computer without interaction with the second computer; and

(c) transmitting the update from the first computer to the second computer.

#### *E. Claim Construction*

Consistent with the statute and the legislative history of the Leahy-Smith America Invents Act,<sup>6</sup> the Board will interpret claims of an unexpired patent using the broadest reasonable construction in light of the specification of the patent. *See* Office Patent Trial Practice Guide, 77 Fed. Reg. at 48,766; 37 C.F.R. § 42.100(b). Claims are to be given their broadest reasonable interpretation consistent with the specification, reading the claim in light of the specification as it would be interpreted by one of ordinary skill in the art. *In re Am. Acad. of Sci. Tech. Ctr.*, 367 F.3d 1359, 1364 (Fed. Cir. 2004).

Unified argues the construction of “signature list,” “update,” “command . . . to copy,” “command to insert,” “determining whether the second computer has a latest version of a file and generating an update, if the second computer does not have a latest version of a file,” “without interaction,” and the preambles for the claims (collectively, “the previously construed terms”) should be the construction given the terms by the Board in

---

<sup>6</sup> Pub. L. 112-29, 125 Stat. 284, 329 (2011).



IPR2013-00073. Pet. 14-16 (citing Ex. 1010 at 7-16). We provide a brief analysis of the construction for each of the previously construed terms below.

1. “signature list”

Unified proposes adopting the construction of a “signature list” as “a collection (*e.g.*, table) of representations of variable length segments of a subject file, which representations serve to identify the segments from which they are determined.” Pet. 14-15 (citing Ex. 1010 at 9). Clouding’s proposed construction is that “a signature list is a collection (*e.g.*, a table) of representations of variable length segments of a subject file, which representations serve to identify the segments from which they are determined,” for example, a table of hashes. Prelim. Resp. 9 (citing Ex. 1001, 8:18-20, 8:29-54, Fig. 4). Therefore, Unified and Clouding propose the same construction for “signature list.”

Figure 4 of the ’799 Patent depicts an exemplary signature list comprising a list of segment locations, sizes, and signatures. The Specification of the ’799 Patent does not provide any specific definition of how the segment identifiers are determined and suggests that the determination may use a hashing method, signature algorithm, or cyclic redundancy check. Ex. 1001, 8:20-28. Therefore, we agree with Unified and Clouding that a “signature list” should be construed as a collection (*e.g.*, table) of representations of variable length segments of a subject file, which representations serve to identify the segments from which they are determined.

2. “*update*”

Unified proposes adopting the construction of “update” as “information for updating a file or an up-to-date version of a file.” Pet. 15 (citing Ex. 1010 at 10). Clouding’s proposed construction is that an “update” is “an item that allows a second computer to build a current version of a file from a local copy of that file.” Prelim. Resp. 10-11 (citing Ex. 1001, 1:24-27; 10:15-22; 11:60-12:13).

The claim term “update” has the following dictionary definition: “current information for updating something” or “*an up-to-date version, account, or report.*”<sup>7</sup> Although the ’799 Patent provides examples where a second computer maintains a version of the file, suggesting that, in some cases, an “update” could be limited to “information for updating a file,” we do not see, nor does Clouding point to, any definition in the Specification of the ’799 Patent excluding a construction encompassing an up-to-date version of a file. Therefore, in the context of file synchronization, we construe the claim term “update” broadly, but reasonably, as information for updating a file or an up-to-date version of a file.

3. “*command . . . to copy*”

Each of claims 1, 12, 23, and 30 recites the following claim phrase: “writing *a command* in the update for the second computer *to copy* an old segment of the second computer’s copy of the earlier version of the file into the second computer’s copy of the current version of the file.” Ex. 1001, claims 1, 12, 23, 30 (emphasis added). Hereinafter, we refer to this claim phrase as “command . . . to copy.”

---

<sup>7</sup> MERRIAM-WEBSTER DICTIONARY, <http://www.merriam-webster.com/dictionary/update> (last visited Feb. 11, 2014) (emphasis added).

Unified proposes adopting the construction of “command . . . to copy” as “an instruction that causes the computer to duplicate information or data.” Pet. 15 (citing Ex. 1010 at 11). Clouding argues the only construction of “command . . . to copy” that is consistent with the language of the claim is a plain meaning “that a *command to copy* be written into the update.” Prelim. Resp. 4-7. Clouding points to examples in the Specification of the ’799 Patent, which Clouding asserts support its position that the claim phrase “command . . . to copy” requires that “a command to copy be written in the update.” Prelim. Resp. 5-7 (citing Ex. 1010 11:19-23; 11:47-12:13; Figs 10 and 11).

We note that the recited language merely requires that a command that causes the second computer to copy a portion of a file be written in the update. The claim does not limit the command to a specific format. Therefore, we broadly, but reasonably, construe “command . . . to copy” as “an instruction that causes the computer to duplicate information or data.”

4. “*command . . . to insert*”

Each of claims 1, 12, 23, and 30 recites the following claim phrase: “writing a *command* in the update for the second computer *to insert* a new segment of the current version of the file into the second computer’s copy of the current version of the file.” Ex. 1001, claims 1, 12, 23, 30 (emphasis added). Hereinafter, we refer to this claim phrase as “command . . . to insert.”

Unified proposes adopting the construction of “command . . . to insert” as “an instruction that causes the computer to put or introduce certain information or data into another file.” Pet. 15 (citing Ex. 1010 at 13-14).

Clouding does not present a proposed construction of “command . . . to insert.”

Similar to the claim phrase “command . . . to copy,” the claim language of the phrase “command . . . to insert” does not limit the claimed “command” to any specific format or form written in the update file for instructing the second computer to perform the function “to insert.” The claim term “insert” ordinarily is understood as “to put or introduce into the body of something.”<sup>8</sup>

Therefore, for purposes of this decision, in the context of the Specification of the ’799 Patent and the claimed subject matter, we construe the claim phrase “command . . . to insert” to mean an instruction that causes the computer to put or introduce certain information or data into another file.

5. *“determining whether the second computer has a latest version of a file” and “generating an update, if the second computer does not have a latest version of the file”*

Unified proposes adopting the construction of “determining whether the second computer has a latest version of a file” and “generating an update, if the second computer does not have a latest version of a file” as not requiring the second computer to possess some version of the file prior to “transmitting the update from the first computer to the second computer.” Pet. 15 (citing Ex. 1010 at 14). Clouding asserts the plain meaning of these phrases requires “the second computer [to] currently possess some version of the file.” Prelim. Resp. 7. Clouding argues “[b]y articulating a process that requires a first computer to determine whether a second computer *has* a

---

<sup>8</sup> MERRIAM-WEBSTER DICTIONARY, <http://www.merriam-webster.com/dictionary/insert> (last visited Feb. 11, 2014).

copy of a file (i.e., a latest version of that file), claims 37 and 42 necessarily impl[y] that the second computer must already possess some version of the file.” *Id.* To support its contention, Clouding directs our attention to the Specification of the ’799 Patent (specifically, “the present invention involves the synchronization of the local copies of files on user’s [sic] client computer hard disk to the current versions of the files on a network drive”), and to its discussion regarding the “copy command.” Prelim. Resp. 7-8 (quoting Ex. 1001, 1:24-27).

The portion of the Specification of the ’799 Patent cited by Clouding does not provide a specific definition that supports Clouding’s proposed construction to require the additional limitation. Nothing in the claim or the Specification of the ’799 Patent requires that a prior version must exist already at the second computer. In a case where no copy of the relevant file exists at the second computer, the recited determining step would determine that the second computer does not have a latest version (or any version) of a file, resulting in the generating step generating an update, which we have construed as information for updating a file or an up-to-date version of a file. Requiring the second computer to have a copy of the file would be importing a limitation from the specification into the claim, which we decline to do. *See In re Van Geuns*, 988 F.2d 1181, 1184 (Fed. Cir. 1993) (“[L]imitations are not to be read into the claims from the specification.”).

Therefore, for purposes of the decision, we determine the phrases “determining whether the second computer has a latest version of a file” and “generating an update, if the second computer does not have a latest version of the file” do not require that the second computer has a copy of the file.

6. “*without interaction*”

Unified proposes adopting the construction of “without interaction” as “limiting the interaction between first and second computers only as specifically recited in the claims.” Pet. 16 (citing Ex. 1010 at 15-16). Clouding does not present a proposed construction of “without interaction.”

We agree with Unified’s proposed construction because it is consistent with the claim language. Specifically, the claims do not require the various computer systems to operate completely independently of one another but only require that a system take certain actions without interaction from another system. For example, the limitation “determining whether the second computer has a latest version of a file, wherein said determining is performed by the first computer *without interaction* with the second computer,” recited in claim 37, merely limits the first computer’s interaction with the second computer in the context of determining whether the second computer has a latest version of a file. By comparison, step (c) of claim 37 does not recite “without interaction,” and, thus, the first computer may interact with the second computer when transmitting the update to the second computer (*see* step (c) of claim 37). For purposes of the decision, we determine “without interaction” merely limits the interaction between first and second computer systems where specifically recited in the claims.

7. *The Preambles*

Unified proposes adopting the determination that the preambles of claims 1, 23, and 37 are limiting. Pet. 16 (citing Ex. 1010 at 16). Clouding does not present a proposal regarding treatment of the preambles.

The language in each preamble provides antecedent basis for many of the important terms in the respective claim body (e.g., “a first computer,”

“an update,” “second computer,” “a copy of a current version of a file,” and “file segments”). Further, the language in each preamble expressly states that the transmission of the update permits the second computer to obtain the most recent version of a file, while the respective claim body may have set forth such a limitation implicitly.

Because the bodies of independent claims 1, 23, and 37 depend on their preambles for completeness, we determine that the preambles of those claims are entitled to patentable weight. *See Catalina Marketing Int’l., Inc. v. Coolsavings.com, Inc.*, 289 F.3d 801, 808 (Fed. Cir. 2002); *Pitney Bowes, Inc. v. Hewlett-Packard Co.*, 182 F.3d 1298, 1305 (Fed. Cir. 1999) (A preamble limits the invention if it recites essential structure or steps, or if it is “necessary to give life, meaning, and vitality” to the claim.).

## II. ANALYSIS

### A. Asserted Anticipation Ground Based on Williams

#### 1. Overview of Williams (Ex. 1006)

Williams describes a fine-grained incremental backup system and process. Ex. 1006, 19:26-22:14. Figure 25 of Williams, reproduced below, illustrates the backup process for two network computers.

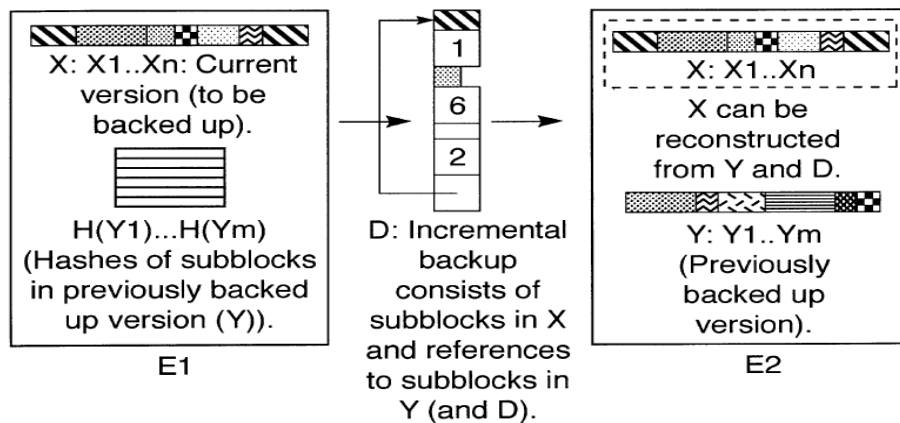

As shown in Figure 25 of Williams, each of the network computers (E1 and E2) has a version of the same file (X and Y). When file X on computer E1 is modified, computer E2 will reconstruct a duplicate version of file X using file Y and the incremental backup file D sent from computer E1 to computer E2, rather than importing the entire file X from computer E1. Ex. 1006, 19:29-34, 19:63-20:2.

For further improvement, Williams indicates that copies of the previous versions of the file system should be retained. Ex. 1006, 21:62-65. This means that computer E2 should maintain both file Y (the previous version) and a duplicate version of file X. *Id.*

As explained in Williams, computer E1 compares the hash of file Y against the hash of file X to determine whether file X has changed. Ex. 1006, 19:44-46. If file X has changed, computer E1 partitions file X into subblocks, and compares the hashes of these subblocks with the hashes of file Y that are stored in shadow file S of computer E1, to find all identical hashes. Ex. 1006, 19:48-51. “Identical hashes identify identical subblocks in [file] Y that can be transmitted by reference.” Ex. 1006, 19:51-52. Computer E1 then transmits the incremental backup file D as a mixture of raw subblocks and references to subblocks whose hashes appear in the



shadow file S and which are known to appear as subblocks in file Y.

Ex. 1006, 19:52-55.

To reconstruct a duplicate version of file X from file Y and incremental backup file D, computer E2 partitions file Y into subblocks and calculates the hashes of subblocks. Ex. 1006, 19:66-20:1. “It then processes the incremental backup information, copying subblocks that were transmitted raw and looking up the references” in file Y. Ex. 1006, 20:2-5.

2. *Analysis of Asserted Ground of Anticipation by Williams*

Unified argues that claims 1, 12, 23, 24, 30, 31, 37, and 42 are anticipated by Williams and provides claim charts reading those claims on Williams, as well as a declaration by Dr. Norman Hutchinson. Pet. 31-40 (citing Ex. 1007 ¶¶ 33, 55-57, 65).

In its Preliminary Response, Clouding argues that Unified fails to establish a reasonable likelihood that claims 1, 12, 23, 24, 30, 31, 37, and 42 are anticipated by Williams. Prelim. Resp. 41-47, 50-51. In particular, with respect to claims 1, 12, 23, 24, 30, and 31, Clouding asserts that “*Williams* does not teach a *command to copy* or a *command to insert*.” Prelim. Resp. 41-47. Regarding claims 37 and 42, Clouding argues Williams “does not teach determining whether the second computer has a latest version of a file and generating an update if the second computer does not have a latest version of the file,” but rather “generates the update when the backup system determines that a backup should be made.” Prelim. Resp. 50-51.

Upon review of Unified’s analysis and supporting evidence, we determine that Unified has demonstrated that there is a reasonable likelihood that it would prevail with respect to claims 1, 12, 23, 24, 30, 31, 37, and 42 on the ground that these claims are anticipated by Williams. We are not

persuaded by Clouding's arguments, as they are based on narrow interpretations of the disputed claim phrases, which we decline to adopt. Furthermore, Clouding fails to consider Williams from the perspective of a person of ordinary skill in the art. *See In re Graves*, 69 F.3d 1147, 1152 (Fed. Cir. 1995) (quoting *In re LeGrice*, 301 F.2d 929, 936 (CCPA 1962)) ("A reference anticipates a claim if it discloses the claimed invention 'such that a skilled artisan could take its teachings in *combination with his own knowledge of the particular art and be in possession of the invention.*'").

Clouding's argument regarding claims 1, 12, 23, 24, 30, and 31 that Williams does not describe the recited "command . . . to copy" is based on Clouding's proposed narrow claim construction, which we decline to adopt. As discussed previously, we construe the claim phrase "command . . . to copy" as *an instruction that causes the computer to duplicate information or data*. Under the proper construction, the claim language does not limit the claimed "command" to a specific format or form.

Clouding fails to recognize that, as explained in Williams, the subblocks of file Y are *duplicated* in computer E2, and that is caused by the instructions in the incremental backup file D. In that regard, Williams describes that the incremental backup file D contains instructions that cause the computer E2 to *duplicate* certain subblocks of file Y, so that a duplicate version of file X is reconstructed from file Y and the incremental backup file D, and computer E2 may maintain both file Y (the previous version) and the duplicate version of file X. Ex. 1006, 19:26-22:14.

Additionally, Clouding's arguments focus narrowly on limited portions of Williams that merely contain the word "copy," without considering the entire disclosure of Williams's fine-grained incremental

backup process relied upon by Unified. *See, e.g.*, Prelim. Resp. 41-43 (citing Ex. 1006, 19:29-34, 22:1-6). Those arguments are misplaced because the reference need not satisfy an *ipsissimis verbis* test to anticipate. *See In re Gleave*, 560 F.3d 1331, 1334 (Fed. Cir. 2009).

We have reviewed Unified's arguments and the supporting citations, and find them persuasive. We conclude that, on this record, Unified has established a reasonable likelihood of prevailing on its anticipation challenge to claims 1, 12, 23, 24, 30, and 31 based on Williams.

With respect to claims 37 and 42, Clouding's argument again is based on Clouding's proposed narrow claim construction of "determining whether the second computer has a latest version of a file" and "generating an update, if the second computer does not have a latest version of the file," which we have not adopted. As previously discussed, we do not construe these phrases as requiring that the second computer has a copy of the file. Clouding argues the first computer cannot determine with certainty whether the second computer has a latest version of a file prior to initiating a backup procedure. Prelim. Resp. 50. Clouding further asserts Williams "generates the update when the backup system determines that a backup should be made." *Id.* at 51.

As discussed above, Clouding fails to consider the portion of Williams describing how a duplicate of the file is reconstructed from the file stored on the second computer and the backup (or difference) file. Ex. 1006, 19:26-22:14. Clouding also fails to consider that Williams discusses initiating a backup action only when the original file has changed. Ex. 1006, 19:49-50.

Therefore, we also find persuasive Unified's arguments and supporting citations regarding claims 37 and 42 and conclude that Unified has established a reasonable likelihood of prevailing on its anticipation challenge to claims 37 and 42 based on Williams.

*B. Asserted Obviousness Ground Based on Williams and Miller*

Unified asserts that claims 5-10, which depend from claim 1, and claims 16-21, which depend from claim 12, are unpatentable under 35 U.S.C. § 103(a) over Williams and Miller. Pet. 40-44. In particular, Unified alleges that the combination of the cited prior art references describes all of the claim limitations and provides a rationale for combining the references. *Id.*

Clouding counters that the combination of Williams and Miller "leads to a difference file without a 'command to copy.'" Prelim. Resp. 48. We are not persuaded by Clouding's arguments. Rather, we determine that Williams describes "command . . . to copy," as recited in claims 1 and 12 for the reasons set forth above.

We have reviewed Unified's analysis and supporting evidence, and determine that Unified's assertion has merit. On this record, Unified has demonstrated that there is a reasonable likelihood that it would prevail with respect to claims 5-10 and 16-21 based on the ground that these claims are unpatentable over Williams and Miller.

*C. Asserted Anticipation Ground Based on Balcha*

*1. Overview of Balcha (Ex. 1003)*

Balcha discloses a method for synchronization of files. Ex. 1003, 1:5-7. In particular, a synchronized file exists on two different servers, and changes made to one file must be reflected in the other file. Ex. 1003, 1:42-

44. Figure 1 of Balcha, reproduced below, illustrates a computer network with two servers using file synchronization.

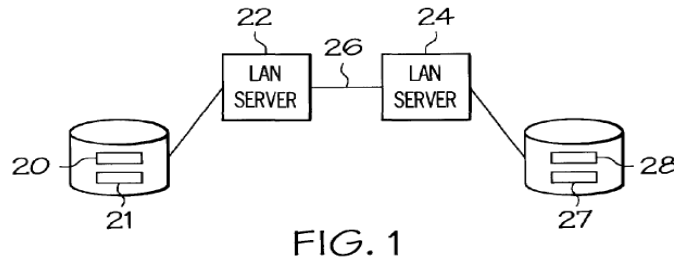

As shown in Figure 1 of Balcha, servers (22 & 24) are interconnected via a network 26, and each server (22 & 24) maintains a copy of a base file (21 & 27) and a base signature file (20 & 28). Ex. 1003, 4:51-53. The base files (21 & 27) should be identical, but either base file can be modified at either server. Ex. 1003, 4:53-61. *Upon detection of a modification to the file*, the detecting server (e.g., server 22), uses the respective base signature file (e.g., base signature file 20) to generate a new delta file, and communicates the delta file over network 26 to server 24. Ex. 1003, 4:61-66 (emphasis added). Server 24 uses the delta file to update the base file 27, and recalculates the base signature file 28. Ex. 1003, 4:66-67. As a consequence, the base files on the servers will stay in synchronization with minimal transfer of data over network 26. Ex. 1003, 5:1-3.

Figure 3 of Balcha, reproduced below, illustrates the relationship of the files.

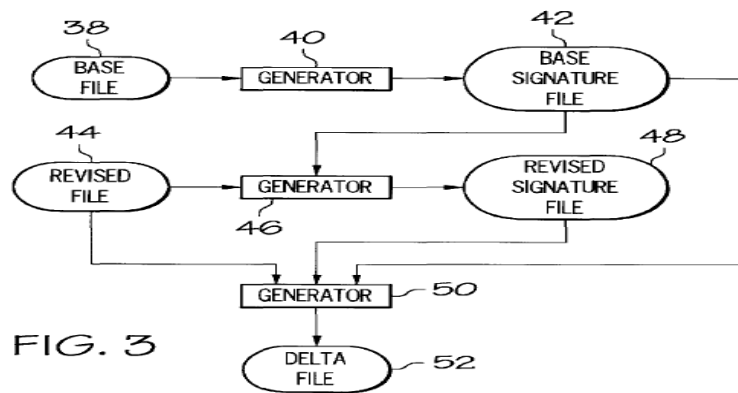

Referring to Figure 3 of Balcha, the base signature file (42) contains a plurality of cyclic redundancy check (CRC) values derived from the data contained in the base file (38). Ex. 1003, 3:1-3, 3:21-28, 7:46-49. When a revised version of the base file (44) is created, a revised signature file (48), including a plurality of revised bit patterns, is generated from the revised file (44). Ex. 1003, 3:4-6, 7:49-53. “Each revised bit pattern is compared to the base bit patterns in base signature file 42.” Ex. 1003, 7:57-59 (emphasis added). “For each revised bit pattern that matches a base bit pattern in base signature file 42, it is stored in revised signature file 48, along with an offset indicating the location in revised file 44 of the beginning of the block of data represented by the revised bit pattern.” Ex. 1003, 7:59-63.

Based on the differences between the base signature file and the revised signature file, a delta file reflecting the differences between the base file and the revised file is generated. Ex. 1003, 3:7-10, 3:50-54. The delta file contains primitives, such as insert, modify, and delete primitives, which are commands that can be applied to a previous version of the file to generate the revised file. Ex. 1003, 3:54-58.

2. *Analysis of Asserted Ground of Anticipation by Balcha*

Unified argues that claims 37 and 42 are anticipated by Balcha and provides claim charts reading those claims on Balcha. Unified also cites the declaration by Dr. Norman Hutchinson. Pet. 26-28 (citing Ex. 1007 ¶¶ 25, 32, 34, 66).

In its Preliminary Response, Clouding argues that Unified fails to establish a reasonable likelihood that claims 37 and 42 are anticipated by Balcha. Prelim. Resp. 20-24. In particular, Clouding asserts that Balcha does not teach “determining whether the second computer has a latest version of a file” and “generating an update if the second computer does not have a latest version of the file,” as recited in claims 37 and 42. *Id.* Specifically, Clouding argues that Balcha generates a new delta file upon detecting a modification to a base file and that the detection of a modification to a base file is not related to determining whether that base file is the latest version of the base file. *Id.* at 22. Rather, Clouding contends, Balcha merely detects a modification to a base file, “regardless of when that modification may have occurred relative to other copies of the same base file.” *Id.* We are not persuaded by Clouding’s arguments as they are based on narrow interpretations of the disputed claim phrases, which we decline to adopt.

As explained by Unified, Balcha’s detecting server determines whether a monitored file has been revised, and a revision to file 21 stored on server 22, for example, indicates that file 27 stored on server 24 is out of date. Pet. 27-28 (citing Ex. 1003, 4:52-67). From the point of view of the computer generating the delta file, the system has determined that the base file is not “a latest version” of the file. Clouding does not provide sufficient

explanation or credible evidence as to why the detection of a file revision does not meet the claim limitation “determining whether a second computer has a latest version of a file.”

We find Unified’s arguments and the supporting evidence persuasive. We conclude that, on this record, Unified has established a reasonable likelihood of prevailing with respect to claims 37 and 42 on the ground that these claims are anticipated by Balcha.

*D. Asserted Obviousness Grounds Based on Balcha and Miller or Balcha, Miller, and Freivald*

Unified asserts that claims 1, 5, 9, 10, 12, 16, 20, 21, 23, 24, 30, and 31 are unpatentable under 35 U.S.C. § 103(a) over Balcha and Miller, and that claims 6-8 and 17-19 are unpatentable over Balcha, Miller, and Freivald. Pet. 16-26, 28-31. In that regard, Unified contends that the combination of cited prior art references describes all of the claim limitations and provides rationales for combining the references. *Id.*

Clouding argues Unified fails to establish a reasonable likelihood that at least one challenged claim is unpatentable. Prelim. Resp. 24-38 (citing Ex. 1004, 2:21-33, 8:27-29). In particular, Clouding contends that a person of ordinary skill in the art would not have combined Balcha and Miller in view of Miller’s stated objective that the DIFF file must be the smallest one possible. Prelim. Resp. 31-38 (citing Ex. 1004, 2:21-33). According to Clouding, one of ordinary skill in the art would have avoided the usage of a copy command in the DIFF file to reduce the number of bytes needed in the DIFF file. Prelim. Resp. 34-35.

We are not persuaded by Clouding’s arguments. Clouding’s contentions take Miller’s stated objective out of context. Miller’s stated



objective for its own invention cannot be read to eliminate a key element of its invention that is used for achieving the very same objective.

In the background section, Miller discusses the problem associated with large computer files. Ex. 1004, 1:47-57. Specifically, Miller highlights the following:

One obstacle to the frequent revision of large computer files by a manufacturer is the cost of delivering the updated file to the user. *If an entire new revised file must be delivered, the amount of data can be substantial.* Large files typically are as large as ten million characters (10 Megabytes) or larger. Distribution of such files on floppy disk can require a relatively large amount of disk space. *Distribution of such large files over a medium such as the Internet can take an undesirably long time from the point of view of the customer and can consume a large amount of server resources from the point of view of the file provider.*

*Id.* (Emphasis added).

To solve the problem of distributing large revised files to customers, Miller provides a method and file structure for generating a DIFF file from an old file and a new file so that the DIFF file can be transmitted to a second computer, rather than transmitting the entire revised file. Ex. 1004, 2:38-46. An important feature of Miller's invention that minimizes the number of bytes being transmitted is the usage of a copy command in the DIFF file. Ex. 1004, 2:51-60. The second computer uses the DIFF file and the old file to create a duplicate version of the new file. *Id.* As a result, transmitting the entire revised file to the second computer is avoided by using the copy command. Accordingly, contrary to Clouding's contentions, Unified has made a sufficient showing that a person of ordinary skill in the art would not have eliminated the usage of a copy command.

Clouding also alleges that the Petition lacks any showing that a person of ordinary skill in the art at the time of the invention would have selected and combined those prior art elements to arrive at the claimed invention. Prelim. Resp. 31-32. We disagree. In its Petition, Unified provides a rationale with sufficient technical reasoning to combine the disclosures of Balcha and Miller. Pet. 17. Unified explains that Balcha and Miller have a “similar purpose of sending delta files to enable remote nodes to update target files.” Pet. 17. Unified asserts that Miller’s commentary about what was known in the art would have led an ordinarily skilled artisan to apply Miller’s teaching of delta files for updating software to Balcha’s method for updating data files in view of Miller’s. Pet. 17. Finally, Unified submits that “substitution of data with software files and substitution of self-executing files for manually executed files were entirely predictable and well known design choices.” Pet. 17.

As argued by Clouding, Balcha describes converting the old file to the revised file directly through execution of the insert and delete instructions included in the delta file. Prelim. Resp. 33 (citing Ex. 1003, 13:64-65). In such a situation, the revised file would replace the old file and, therefore, the second computer would not have a version of the old file (i.e., the previous version).

However, Miller describes a DIFF file that includes *a copy command*. Ex. 1004, 8:27-29, Fig. 5A. Additionally, Dr. Hutchinson’s declaration points to Balcha’s recognition of the value of saving multiple versions of a file at a second computer. Ex. 1007, ¶45 (citing Ex. 1003, 5:22-23). Accordingly, Clouding’s argument that one of ordinary skill in the art would not have used Miller’s copy command in the combination of Balcha and

Miller “because the revised file [in Balcha] is itself directly produced from the old file and the difference file” is unpersuasive. Prelim. Resp. 33.

For the foregoing reasons, we determine that Unified has demonstrated a reasonable likelihood that it would prevail with respect to: (1) claims 1, 5, 9, 10, 12, 16, 20, 21, 23, 24, 30, and 31 based on the ground that these claims would have been obvious over Balcha and Miller; and (2) claims 6-8 and 17-19 based on the ground that these claims would have been obvious over Balcha, Miller, and Freivald.

*E. Asserted Obviousness Grounds Based on Balcha and Freivald*

Unified asserts that claims 37 and 42 are unpatentable under 35 U.S.C. § 103(a) over Balcha and Freivald. Pet. 45-57.<sup>9</sup> Unified raises this challenge in response to Clouding’s argument, previously made in IPR2013-00073, that Balcha does not anticipate claims 37 and 42 because Balcha does not teach “determining whether a second computer has a latest version of a file.” Pet. 46. Unified asserts the combination of Balcha and Freivald describes all of the claim limitations of claims 37 and 42 and provides rationales for combining Balcha and Freivald. Pet. 45-47, 54-57.

Unified’s challenge of claims 37 and 42 relies on a combination of Balcha and Freivald for teaching “determining whether a second computer has a latest version of a file.” Unified argues Freivald’s disclosure of a change-detection server or “minder” teaches determining “whether the client computer has the most recent version of a web page document and, if the client’s version is out of date, transmit[ing] an updated copy of the

---

<sup>9</sup> Unified also asserts claims 1, 12, 23, 30, and 31 are unpatentable under 35 U.S.C. § 103(a) over Balcha and Miller. Regarding this challenge, *see* Section II.F.

document to the client computer.” Pet. 55-56 (citing Ex. 1005, 6:61-67, 7:25-39). Unified particularly points to Freivald’s disclosure regarding a “Minder” that regularly retrieves registered documents and determines whether a change has occurred to that document. Pet. 56 (quoting Ex. 1005, 6:61-67). Unified further points out that Freivald may use a date or time-stamp comparison to determine whether a document has been modified and, thus, determines “whether a second or client computer has the latest version of the document,” using the same method disclosed in the ’799 Patent. *Id.* (citing Ex. 1005, 2:31-36; Ex. 1001, 6:57-63).

Clouding argues Unified fails to establish a reasonable likelihood that at least one challenged claim is unpatentable. Prelim. Resp. 38-41 (citing Ex. 1005, 5:24-29, 7:3-54). In particular, with respect to claims 37 and 42, Clouding contends that neither Balcha nor Freivald teaches “determining whether the second computer has a latest version of a file [and] generating an update, if the second computer does not have a latest version of the file,” as recited in claims 37 and 42. Prelim. Resp. 40. According to Clouding, Freivald “is unconcerned with whether the client computer has any copy of the file.” *Id.* Specifically, Clouding asserts Freivald sends notifications upon detecting changes to a document regardless of whether or not the client has a latest version. *Id.*

As already discussed, Balcha determines whether a base file has been changed and, if so, sends a delta file for use by another system to update its base file. *See* Section II.C. Freivald uses a time-stamp to detect whether a document has changed since the last time it was sent to a client. *See* Ex. 1005, 6:20-67. Given the disclosures of Balcha and Freivald, we determine that Unified has demonstrated a reasonable likelihood that it

would prevail with respect to claims 37 and 42 based on the grounds that these claims would have been obvious over Balcha and Freivald.

*F. Additional Asserted Grounds*

Unified also asserts that claim 1, 12, 23, and 30 would have been obvious over Balcha and Freivald. Pet. 45-56. That asserted ground is redundant in light of the determination that there is a reasonable likelihood that the challenged claims are unpatentable based on the grounds of unpatentability on which we institute an *inter partes* review. See 37 C.F.R. § 42.108(a).

III. CONCLUSION

Unified has shown a reasonable likelihood that it would prevail in demonstrating unpatentability of each of claims 1, 5-10, 12, 16-21, 23, 24, 30, 37, and 42, on at least one challenged ground. The Board has not made a final determination on the patentability of any challenged claim under 35 U.S.C. § 318(a).

IV. ORDER

For the reasons given, it is

ORDERED that an *inter partes* review of claims 1, 5-10, 12, 16-21, 23, 24, 30, 37, and 42 is instituted on the following claims and challenged grounds:

(a) that claims 1, 12, 23, 24, 30, 31, 37, and 42 are unpatentable as anticipated by Williams under 35 U.S.C. § 102(e);

(b) that claims 5-10 and 16-21 are unpatentable as obvious over Williams and Miller under 35 U.S.C. § 103(a);

(c) that claims 37 and 42 are unpatentable as anticipated by Balcha under 35 U.S.C. § 102(e);

(d) that claims 1, 5, 9, 10, 12, 16, 20, 21, 23, 24, 30, and 31 are unpatentable as obvious over Balcha and Miller under 35 U.S.C. § 103(a);

(e) that claims 6-8 and 17-19 are unpatentable as obvious over Balcha, Miller, and Freivald under 35 U.S.C. § 103(a); and

(f) that claims 37 and 42 are unpatentable as obvious over Balcha and Freivald under 35 U.S.C. § 103(a);

FURTHER ORDERED that the trial is limited to the grounds enumerated in the previous paragraphs and on no other grounds;

FURTHER ORDERED that pursuant to 35 U.S.C. § 314(c) and 37 C.F.R. § 42.4, notice is hereby given of the institution of a trial; the trial commences on the entry date of this decision; and

FURTHER ORDERED that an initial conference call with the Board is scheduled for 2 PM Eastern Time on April 21, 2014. The parties are directed to the Office Patent Trial Practice Guide, 77 Fed. Reg. 48,756, 48,765-66 (Aug. 14, 2012) for guidance in preparing for the initial conference call, and should be prepared to discuss any proposed changes to the Scheduling Order entered herewith and any motions the parties anticipate filing during the trial.

IPR2013-00586  
Patent 6,738,799 B2

PETITIONER:

Michael L. Kiklis  
Scott A. McKeown  
OBLON SPIVAK  
1940 Duke Street  
Alexandria, VA 22314  
cpdocketkiklis@oblon.com  
cpdocketmckeown@oblon.com

PATENT OWNER:

Tarek N. Fahmi  
Amy J. Embert  
FAHMI, SELLERS & EMBERT  
84 W. Santa Clara St., Suite 550  
San Jose, CA 94113  
tarek.fahmi@fseip.com  
amy.embert@fseip.com