

UNITED STATES PATENT AND TRADEMARK OFFICE

BEFORE THE PATENT TRIAL AND APPEAL BOARD

UNIFIED PATENTS INC.,
Petitioner,

v.

iMTX STRATEGIC, LLC,
Patent Owner.

Case IPR2015-01061
Patent 7,269,854 B2

Before THOMAS L. GIANNETTI, JAMES B. ARPIN, and
MATTHEW R. CLEMENTS, *Administrative Patent Judges*.

GIANNETTI, *Administrative Patent Judge*.

DECISION
Institution of *Inter Partes* Review
37 C.F.R. § 42.108

Unified Patents Inc. (“Petitioner”) filed a Petition pursuant to 35 U.S.C. §§ 311–319 to institute an *inter partes* review of claims 1–23 (all claims) of U.S. Patent No 7,269,854 B2, issued on September 11, 2007 (Ex.

1001, “the ’854 patent”). Paper 1 (“Pet.”). iMTX Strategic, LLC (“Patent Owner”) filed a Preliminary Response. Paper 6 (“Prelim. Resp.”). Applying the standard set forth in 35 U.S.C. § 314(a), which requires demonstration of a reasonable likelihood that Petitioner would prevail with respect to at least one challenged claim, we grant Petitioner’s request and institute an *inter partes* review of all challenged claims.

I. BACKGROUND

A. The ’854 patent (Ex. 1001)

The ’854 patent is entitled “Transaction System for Transporting Media Files from Content Provider Sources to Home Entertainment Devices.” The Abstract describes the subject matter as follows:

A system and method for enabling a user to request and download selected media files from distributed content provider sites via the Internet. The system includes a plurality of user sites each including a player/receiver housed in an enclosure having a simple user interface, a plurality of content provider sites, and a transaction server site. The player/receiver enables the user to connect to the transaction server via the Internet to access a program guide listing available media files. The user is then able to select a desired file and, via the player/receiver and Internet, request the transaction server to authorize download of the selected file. The file request along with file encryption and transfer instructions are sent from the transaction server via the Internet to the content provider site storing the requested file. Requested files are then dynamically encrypted by the content provider site and securely downloaded to the requesting player/receiver. The requesting player/receiver is uniquely capable of decrypting a downloaded file concurrent with playing back the file on a conventional home television set and/or audio system.

Ex. 1001, Abstract. This is illustrated by Figure 1 of the patent which is reproduced below:

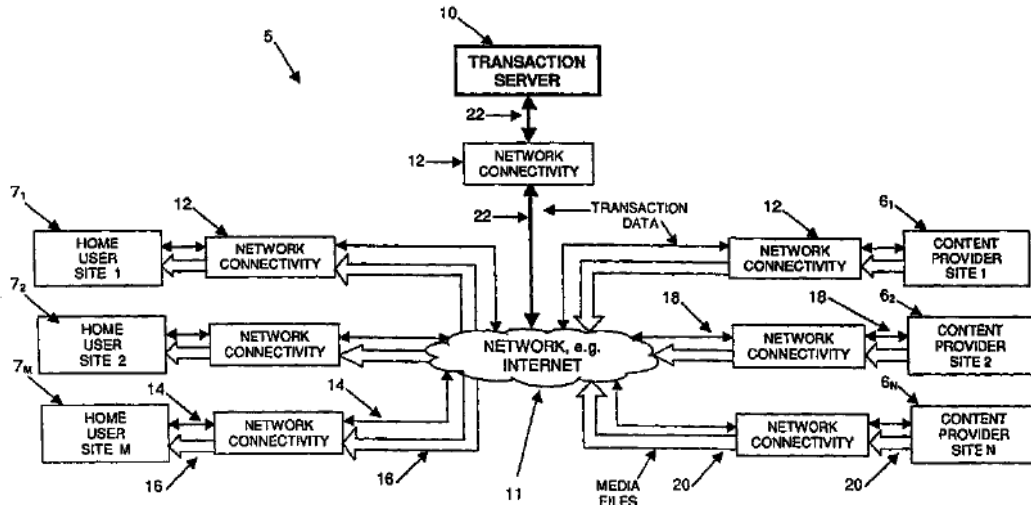

Figure 1 above is a block diagram showing the architecture of a preferred system in accordance with the invention. Ex. 1001, col. 3, ll. 66–67. The system is comprised of a plurality of content provider sites 6₁, 6₂, etc., a plurality of home user sites 7₁, 7₂, etc., and transaction server site 10. Each of these is connected to a common communications network 11. *Id.* at col. 4, ll. 31–36. In the preferred embodiment, network 11 is the public Internet. *Id.* at col. 4, ll. 37–38. In alternative embodiments, however, network 11 could comprise other public or private networks. *Id.* at col. 4, ll. 42–44.

In the preferred embodiment, connections to the Internet are formed by a suitable broadband network connectivity device 12. Examples include cable modems, digital subscriber lines, or very small satellite Internet access systems. *Id.* at col. 4, ll. 38–41.

B. Illustrative Claim

Claims 1 and 14 are independent claims. Claim 1 is illustrative of the claims at issue and is reproduced below:

1. A system for executing user transaction requests for delivering digital media files via the Internet for driving a user site television set and/or audio equipment, said system comprising:

a plurality of user sites, each user site including a player/receiver, a television set and/or audio equipment, and a connectivity device for connecting said player/receiver to the Internet;

a plurality of provider sites, each provider site including a media server comprising a media file storage device and a media file encryptor, and a connectivity device for connecting said provider site media server to the Internet;

a transaction server and a connectivity device for connecting said transaction server to the Internet;

each said player/receiver including a user interface for sending a media file request via the Internet to said transaction server requesting delivery of an identified media file;

said transaction server being responsive to a received media file request for sending an authorization to the provider site storing the requested media file authorizing delivery of the requested media file from said provider site to the requesting player/receiver directly via the Internet;

said authorized provider site being responsive to said transaction server authorization for uniquely encrypting the identified media file and for downloading the encrypted media file directly via the Internet to said requesting player/receiver;

each said player/receiver including a media file decryptor; and wherein

only said requesting player/receiver decryptor is capable of decrypting said encrypted media file downloaded thereto for playback on the television set and/or audio equipment at the same user site.

Claim 14, directed to a method, recites subject matter that is similar to that of claim 1.

C. Related Proceedings

Petitioner and Patent Owner identify a number of related proceedings in the Northern District of California and the District of Delaware involving the '854 patent. Pet. 2–3, Paper 5, 2–3.

D. Real Party-in-Interest

Petitioner certifies that Unified Patents Inc. is the real party-in-interest, and “further certifies that no other party exercised control or could exercise control over Unified’s participation in this proceeding, the filing of this petition, or the conduct of any ensuing trial.” Pet. 2. In support of this assertion, Petitioner has filed “voluntary interrogatory responses,” signed by its counsel and verified by its CEO. Ex. 1018.

Patent Owner contends that the Petition should be denied for failure to name the real party-in-interest. Prelim. Resp. 12. Patent Owner asserts that Unified is not the real party-in-interest because “Unified’s only source of revenue is subscription fees that are paid by its subscribers so Unified can file post-grant proceedings on behalf of its subscribers.” *Id.* at 12–13.

Patent Owner fails to provide persuasive evidence that Petitioner is not the sole real party-in-interest. Whether a particular entity is a real party-in-interest is a “highly fact-dependent question” that is assessed “on a case-by-case basis.” Office Patent Trial Practice Guide, 77 Fed. Reg. 48,756, 48,759 (Aug. 14, 2012) (citing *Taylor v. Sturgell*, 553 U.S. 880, 893–95 (2008)). While multiple factors may be relevant to the inquiry, “[a] common consideration is whether the non-party exercised or could have exercised

control over a party's participation in a proceeding.” *Id.* See also *Zoll Lifecor Corp. v. Philips Elec. North Am. Corp.*, Case IPR2013-00609, slip op. at 10 (PTAB Mar. 20, 2014) (Paper 15). Patent Owner presents no evidence to rebut Petitioner's assertion that no other party controls or could control this proceeding. Accordingly, we are persuaded at this stage that the real parties-in-interest have been named in the Petition.

Patent Owner's reliance on the “Troll Busters” decision (*In re Guan Inter Partes Reexamination Proceeding*, Control No. 95/001,045, Decision Vacating Filing Date (Aug. 25, 2008)) is misplaced. Among other reasons, in *Guan*, there was evidence that unnamed parties picked the patents to be challenged and provided funding for the particular proceedings. In contrast, the record here indicates that, in this proceeding, Petitioner is acting without control from its subscribers and is not receiving financing from them to bring this particular proceeding. Ex. 1018.

Consequently, on this record, we are not persuaded that the Petition should be denied for failure to name the real party-in-interest.

E. Claim Construction

In an *inter partes* review, claim terms in an unexpired patent are construed according to their broadest reasonable interpretation in light of the specification of the patent in which they appear. 37 C.F.R. § 42.100(b); Office Trial Practice Guide, 77 Fed. Reg. 48,756, 48,766 (Aug. 14, 2012); *In re Cuozzo Speed Techs., LLC*, 793 F.3d 1268, 1275–79 (Fed. Cir. 2015). Under that standard, claim terms are given their ordinary and customary meaning, as would be understood by one of ordinary skill in the art in the context of the entire disclosure. *In re Translogic Tech., Inc.*, 504 F.3d 1249, 1257 (Fed. Cir. 2007).

The only claim term for which Petitioner proposes a construction is a means-plus-function term in dependent claims 9 and 10. Pet. 10. Those claims recite: “means for displaying a program guide listing media files stored by the digital storage device therein.” *Id.* Petitioner identifies the function as “displaying a program guide listing media files stored by the digital storage.” *Id.* at 11. Petitioner identifies the associated structure as a conventional, home television set. *Id.* Patent Owner agrees with the Petitioner’s statement of the function. Prelim. Resp. 20. As to the associated structure, Patent Owner identifies player/receiver subsystem 30 in Figure 2, television/video display interface 40, and “conventional” television/video display 42. Ex. 1001, col. 5, ll. 14–18. Independent claim 1, from which claim 9 depends, already recites a “player/receiver.” Thus, we are not persuaded that player/receiver subsystem 30, or television video display interface 40 contained therein, should be included as structure that performs the further limitation of “displaying” recited in dependent claim 9. We, therefore, determine that the supporting structure is a conventional, television/video display.

Patent Owner contends that Petitioner has failed to construe “key terms,” making evaluation of the merits of the Petition “impossible.” Prelim. Resp. 19. In that regard, Patent Owner proposes constructions for the terms “Internet,” “transaction server,” and “encrypted media file.” *Id.* at 21–26. We have reviewed these proposals and are not persuaded that construction is necessary for these terms beyond their plain meanings. For example, Patent Owner asserts that as to the term “Internet,” the “applicant chose to be his own lexicographer and provided an explicit definition.” *Id.* at 24. The ’854 patent Specification, however, specifically refers to the

“public Internet.” Ex. 1001, col. 4, ll. 37–38. This persuades us that no special definition beyond the plain meaning of the term is necessary.

Likewise, we are not persuaded that special constructions of “transaction server,” and “encrypted media file” are necessary. We, therefore, rely on the plain meanings for those terms.

Finally, Patent Owner proposes a special construction for certain terms relating to the downloading and encryption of data files. Prelim. Resp. 27–30. Patent Owner’s construction would add the limitation “without the media file having to be stored or processed by the translation server and with no involvement by the transaction server in the downloading, such that the media file can only be played back on the requesting player/receiver.” *Id.* at 30. This proposed construction would rewrite the claims. We are not persuaded that it is consistent with the broadest reasonable interpretation. We, therefore, will rely on the plain meaning of the claim language for these limitations.

Accordingly, we are not persuaded by Patent Owner’s argument that institution should be denied because Petitioner failed to submit claim constructions for “key terms.” Prelim. Resp. 19–20.

F. References

Petitioner relies on the following three references:

1. U.S. Patent No. 6,055,314 to Spies, Apr. 25, 2000 (Ex. 1006)
2. U.S. Patent No. 5,956,716 to Kenner, Sept. 21, 1999 (Ex. 1007)
3. Roger E. Libman, et al, *The Interactive Video Network: An Overview of the Video Manager and V Protocol*, AT&T Tech. J., Sept./Oct. 1995 (Ex. 1009) (hereinafter “Libman”).

G. Grounds Asserted

Petitioner challenges the patentability of claims 1–23 of the ’854 patent on the following grounds:

1. Obvious over Libman and Spies under 35 U.S.C. § 103(a), and
2. Obvious over Kenner and Spies under 35 U.S.C. § 103(a).

II. ANALYSIS

A. Asserted Ground Based on Libman and Spies

Petitioner contends that the subject matter of claims 1–23 would have been obvious over Libman and Spies in combination. Pet. 11–42. We have reviewed the information provided by Petitioner, including the claim chart analysis and supporting Declaration of Dr. Charles A. Eldering (Ex. 1002, “Eldering Decl.”), and are persuaded that, based on this record, Petitioner has demonstrated a reasonable likelihood of prevailing on this challenge.

1. Libman Overview

Libman describes a network architecture that allows users to search for and download interactive multimedia services including video. Eldering Decl. ¶ 40. This architecture is illustrated by annotated Figure 2 of Libman, which is reproduced below with red directional arrows provided by Petitioner (*id.* at ¶ 41):

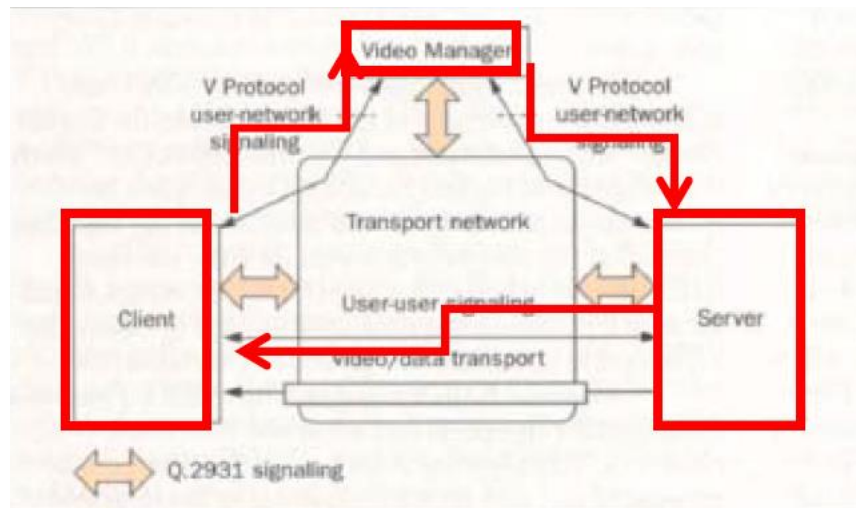

Figure 2 of Libman, reproduced above, shows a triangular network architecture whereby a client, using a V protocol, contacts a video manager through a transportation network. Eldering Decl. ¶ 41. The Video Manager contacts a server hosting content. *Id.* The Video Manager then takes that request, identifies a server where the desired item is stored, and opens a session allowing the server to transport multimedia files directly to the client. *Id.* The Video Manager, thus, contacts the server and authorizes the server to transport multimedia files to the client. Pet. 12. Libman discloses a system architecture where multiple users can use the system to contact multiple content providers through network intermediaries. *Id.* Because the transmission medium is shared, Libman also discloses using encryption to control access and privacy. *Id.* at 14.

2. Spies Overview

Spies discloses a system and method for secure purchase and delivery of video content programs over various distribution media, including distribution networks. Ex. 1006, Abstract, col. 2, ll. 26–29. The system includes an integrated circuit card (“IC”) that is configured to store decryption information for related video programs. *Id.*, Abstract. When a

purchaser orders a particular video program, the decryption capabilities for that program are downloaded by the video merchant to the IC card, either at the merchant's premises or over a distribution network. *Id.* Video content programs are distributed in encrypted format by the distribution medium to the purchaser. The IC card uses the decryption capability to at least partially decrypt video content program. *Id.*

Spies teaches the use of various encryption techniques that allow the video merchant to encrypt a media file. In one embodiment, a secure key is provided from a secure key store. Ex. 1006, Fig. 1, col. 5, ll. 10–53. Spies describes a video purchase and delivery system in which the video content program is delivered in encrypted format to the purchaser via a distribution medium. *Id.*, Fig. 2, col. 5, l. 56–col. 6, l. 10. The video content is delivered in encrypted format to the purchaser via the distribution medium. The purchaser uses a specially coded IC card to decrypt the video content. *Id.*, Fig. 3, col. 8, l. 60–col. 9, l. 51.

3. Discussion

Patent Owner's Preliminary Response is directed to claims 1 and 14 only, and does not argue separately the patentability of the dependent claims. Prelim. Resp. 31. We, therefore, treat claims 1 and 14 as representative of all challenged claims and do not discuss separately the challenged dependent claims.

Petitioner's claim charts demonstrate where each element of claims 1 and 14 is found in the Libman-Spies combination. For example, Petitioner identifies the recited "player/receiver" with the disclosure of a personal computer, workstation, or television set top box in Libman. Pet. 19.

Petitioner also identifies this element with the set-top box and television disclosed in *Spies*. *Id.*

Petitioner also provides a persuasive rationale for combining the teachings of Libman and *Spies*. Pet. 15–17. Petitioner acknowledges that Libman generally discloses encryption to control access and privacy over a shared transmission medium. *Id.* at 14. But according to Petitioner, a person of ordinary skill would have been motivated to apply the various encryption techniques described in *Spies* to increase security further. *Id.* at 16–17.

Patent Owner criticizes Petitioner’s analysis and claim charts on a number of grounds. For example, Patent Owner asserts that Petitioner fails to identify the differences between the claims and the “primary” reference and, thus, fails to show how the “secondary” reference “remedies the deficiencies in the primary reference.” Prelim. Resp. 33 n.2, 42. We are not persuaded by this argument. As noted above, Petitioner has explained that “*Spies* teaches and discloses the use of a variety of encryption techniques which allows for the video merchant to encrypt a video file.” Pet. 14. We are satisfied that Petitioner has sufficiently explained the reasons for its reliance on *Spies* in combination with Libman.

Next, Patent Owner contends that Petitioner fails to show how the applied art teaches certain “functional relationships” recited in the claims. Prelim. Resp. 34. As an example, Patent Owner cites the claim language: “for sending an authorization to the provider site storing the requested media file authorizing delivery of the requested media file from said provider site to the requesting player/receiver.” Patent Owner contends that Petitioner has failed to show how this limitation is met by *Spies*. *Id.* at 34–35. We are not

persuaded by this argument. The description of Libman, above, and in Petitioner's claim charts demonstrate that this element is met by Libman. Pet. 22–23. In Libman, the Video Manager authorizes the server to transport multimedia files to the client. Pet. 12; Ex. 1009, 7.

Patent Owner contends that we should give “no weight” to Dr. Eldering's Declaration. Prelim. Resp. 36. According to Patent Owner, Dr. Eldering analyzed the claims using the incorrect definition for the term “Internet.” *Id.* We are not convinced by this argument. As discussed above, we do not accept Patent Owner's argument that the '854 patent specification provides a special definition for the term “Internet” beyond its plain and ordinary meaning. In that regard, the descriptions of the Internet set forth by Patent Owner (Prelim. Resp. 23–24) and in the '854 patent (Ex. 1001, col. 4, ll. 44–47) are consistent with the plain meaning. In addition, a relevant definition of the “Internet” is “[t]he worldwide collection of networks and gateways that use the TCP/IP suite of protocols to communicate with one another.” MICROSOFT COMPUTER DICTIONARY 242 (4th Ed. 1999) (Ex. 3001).

Moreover, we are persuaded that the combination of Libman and Spies discloses the “Internet” under the plain meaning of that term. Even assuming that Libman's disclosed network does not disclose the “Internet,” Spies discloses expressly that the communications described therein may occur over the Internet (*see, e.g.*, Pet. 19), as Patent Owner acknowledges later in its Preliminary Response (Prelim. Resp. 49–50). As the Federal Circuit reminded in *Western Union Co. v. MoneyGram Payment Sys., Inc.*, 626 F.3d 1361, 1370 (Fed. Cir. 2010), “applying computer and internet

technology to replace older electronics has been commonplace in recent years.”

We have considered Patent Owner’s other arguments regarding this ground of challenge and find them unpersuasive.

B. Asserted Ground Based on Kenner and Spies

Petitioner’s second ground contends that the subject matter of claims 1–23 would have been obvious over Kenner and Spies. Pet. 42–60. We have reviewed the information provided by Petitioner and are persuaded that, based on this record, Petitioner has demonstrated a reasonable likelihood of prevailing on this challenge.

1. Kenner Overview

Kenner describes an Internet-based video storage and retrieval system. Pet. 43; Ex. 1007, Abstract, Fig. 1. The system architecture is illustrated by annotated Figure 1 of Kenner, which is reproduced below with red directional arrows provided by Petitioner (Pet. 43):

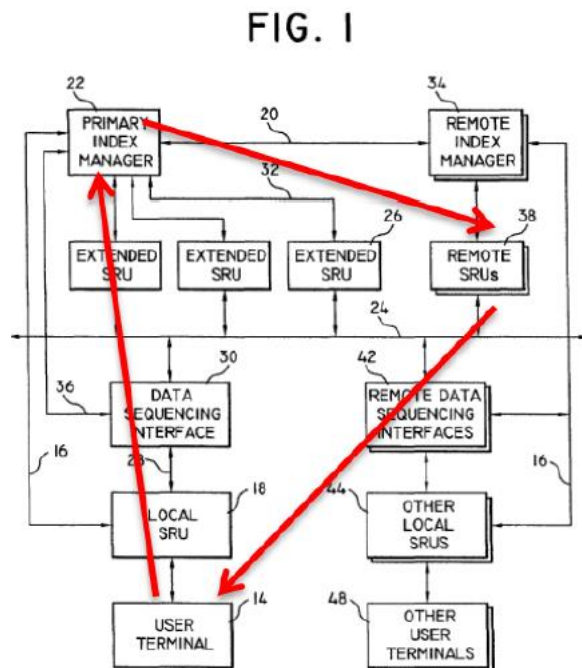

As shown in Figure 1 of Kenner, reproduced above, video clips are stored on extended storage and retrieval units (“SRUs”). The users obtain videos by contacting the primary index manager (“PIM”) via the local SRU. Ex. 1007, col. 7, ll. 23–27. The PIM locates the video and creates a data sequencing interface (“DSI”) to direct the download to the user terminal. *Id.* at col. 7, ll. 27–29. The DSI supervises communications between the remote SRUs storing the requested information and the local SRU. *Id.* at col. 12, ll. 5–15. The local SRU downloads the compressed video to the user’s terminal. *Id.* at col. 9, ll. 31–32. Kenner discloses storing the video stream in an encrypted state via known encryption methods, such as DES and RSA. *Id.* at col. 25, ll. 60–62.

2. Discussion

Petitioner’s detailed claim charts demonstrate where each element of claims 1 and 14 is found in the Kenner-Spies combination. Pet. 47–60. For example, Petitioner identifies the recited “player/receiver” with the disclosure of a personal computer, workstation, or television set top box in Kenner. Pet. 47.

Petitioner also provides a persuasive rationale for combining the teachings of Kenner and Spies. Pet. 44–47. Petitioner acknowledges that Kenner discloses storing the video stream in an encrypted state via known encryption methods, and even gives as examples DES and RSA. *Id.* at 44. According to Petitioner, a person of ordinary skill would have had reason to combine the conventional existing encryption algorithms described in Spies to avoid the disadvantages of a “massive parallel system” disclosed in Kenner. Pet. 44 (citing Eldering Decl. ¶¶ 66–68). Further reasons for

combining Kenner and Spies are provided at pages 45–47 of the Petition and paragraphs 69–84 of the Eldering Declaration.

Patent Owner responds to this challenge by relying on a construction of claims 1 and 14 that we did not adopt. According to the Patent Owner, Kenner does not meet the requirement of: “transferring [the] media file from a provider site to a user site via the Internet *without the media file having to be stored or processed by the transaction server and with no involvement by the transaction server in the downloading*, such that the media file can only be played back on the requesting player/receiver.” Prelim. Resp. 48–49. As we explain above, this construction rewrites the claims and is not consistent with the broadest reasonable interpretation. We, therefore, are not persuaded by Patent Owner’s argument attempting to distinguish Kenner based on this construction.

In responding to this challenge, Patent Owner repeats several arguments addressed above. For example, Patent Owner asserts that Petitioner has failed to analyze the differences between “primary” and “secondary” references, and that Spies fails to describe the functional relationship between the transaction server and the provider site. Prelim. Resp. 50–53. We are not persuaded by these arguments for at least the reasons set forth above. We are persuaded, instead, that Petitioner’s information, supported by the Eldering Declaration, is sufficient at this stage to demonstrate a reasonable likelihood of prevailing on this challenge.

We have considered Patent Owner’s other arguments regarding this ground of challenge and find them unpersuasive.

II. SUMMARY

The information presented shows there is a reasonable likelihood that Petitioner will prevail on the following challenges to patentability of claims 1–23 the '854 patent:

- A. obviousness over Libman and Spies; and
- B. obviousness over Kenner and Spies.

At this stage of the proceeding, we have not made a final determination as to the patentability of any challenged claim or the construction of any claim term.

IV. ORDER

It is, therefore,

ORDERED that, pursuant to 35 U.S.C. § 314(a), an *inter partes* review is hereby instituted on the following grounds:

- A. Obviousness of claims 1–23 over Libman and Spies; and
- B. Obviousness of claims 1–23 over Kenner and Spies.

FURTHER ORDERED that review based on any other proposed grounds of unpatentability is not authorized; and

FURTHER ORDERED that pursuant to 35 U.S.C. § 314(c) and 37 C.F.R. § 42.4, notice is hereby given of the institution of a trial commencing on the entry date of this decision.

IPR2015-01061
Patent 7,269,854 B2

PETITIONER:

P. Andrew Riley
Linda Thayer
Jonathan Stroud
Joshua Goldberg
FINNEGAN, HENDERSON, FARABOW, GARRETT
& DUNNER, LLP
linda.thayer@finnegan.com
Jonathan.stroud@finnegan.com
iMTX_IPR12897-9003@Finnegan.com

PATENT OWNER:

René A. Vazquez
Maureen V. Abbey
HENINGER GARRISON DAVIS, LLC
rvazquez@hgdllawfirm.com
maureen@hgdllawfirm.com
PG_iMTX@hgdllawfirm.com

kis