

UNITED STATES PATENT AND TRADEMARK OFFICE

---

BEFORE THE PATENT TRIAL AND APPEAL BOARD

---

UNIFIED PATENTS INC.,  
Petitioner,

v.

VILOX TECHNOLOGIES, LLC,  
Patent Owner.

---

Case IPR2018-00044  
Patent 7,302,423 B2

---

Before SALLY C. MEDLEY, ROBERT J. WEINSCHENK, and  
JOHN D. HAMANN, *Administrative Patent Judges*.

HAMANN, *Administrative Patent Judge*.

FINAL WRITTEN DECISION  
*35 U.S.C. § 318(a) and 37 C.F.R. § 42.73*  
DECISION ON MOTION TO AMEND  
*35 U.S.C. § 316(d) and 37 C.F.R. § 42.121*

## I. INTRODUCTION

This *inter partes* review, instituted pursuant to 35 U.S.C. § 314, challenges the patentability of claims 1–9 and 13 (“the challenged claims”) of U.S. Patent No. 7,302,423 B2 (“the ’423 patent,” Ex. 1001), owned by Vilox Technologies, LLC (“Patent Owner”). We have jurisdiction under 35 U.S.C. § 6. This Final Written Decision is entered pursuant to 35 U.S.C. § 318(a) and 37 C.F.R. § 42.73.

For the reasons discussed herein, Unified Patents Inc. (“Petitioner”) has shown by a preponderance of the evidence that (i) the challenged claims of the ’423 patent are unpatentable, and (ii) Patent Owner’s contingent, substitute claims would be unpatentable.

## II. BACKGROUND

### A. Procedural History

On October 6, 2017, Petitioner filed a Petition requesting *inter partes* review of the challenged claims of the ’423 patent. Paper 1 (“Pet.”). The Petition is supported by the Declaration of Philip Greenspun, Ph.D. (“Greenspun Decl.,” Ex. 1005) and the Declaration of Ingrid Hsieh-Yee, Ph.D. (Ex. 1011). Patent Owner filed a Preliminary Response. Paper 7.

On April 19, 2018, we instituted *inter partes* review of all of the challenged claims of the ’423 patent on all of the asserted grounds. Paper 9 (“Inst. Dec.”), 6, 38. On July 9, 2018, Patent Owner filed a Response to the Petition. Paper 26 (“PO Resp.”). The Response is supported by the Declaration of Wesley W. Chu, Ph.D. (“Chu Decl.,” Ex. 2017), the Declaration of Dr. Joseph L. De Bellis (Ex. 2021), and the Declaration of Lucille Marie De Bellis (Ex. 2022). On September 24, 2018, Petitioner filed a Reply to Patent Owner’s Response. Paper 41 (“Pet. Reply”). On

November 6, 2018, Patent Owner filed an amended Sur-Reply to Petitioner's Reply. Paper 52 ("PO Sur-Reply").

In addition, on July 9, 2018, Patent Owner filed a contingent Motion to Amend certain of the challenged claims. Paper 27 ("MTA"), 1–2. On September 24, 2018, Petitioner filed an Opposition to Patent Owner's Motion to Amend. Paper 42 ("MTA Opp."). The Opposition to the Motion to Amend is supported by a separate Declaration of Philip Greenspun, Ph.D. ("Greenspun MTA Decl.," Ex. 1013). On October 22, 2018, Patent Owner filed a Reply to Petitioner's Opposition to Patent Owner's Motion to Amend. Paper 45 ("MTA Reply"). Patent Owner's Reply for the Motion to Amend is supported by a separate Declaration of Wesley W. Chu, Ph.D. ("Chu MTA Decl.," Ex. 2027) and a Declaration of Lucille Marie De Bellis (Ex. 2029). On November 13, 2018, Petitioner filed a Sur-Reply to Patent Owner's Reply to Petitioner's Opposition to Patent Owner's Motion to Amend. Paper 53 ("MTA Sur-Reply").

On November 5, 2018, Patent Owner filed a Motion to Exclude Evidence. Paper 49 ("Mot. Ex. Ev."). On November 16, 2018, Petitioner filed an Opposition to Patent Owner's Motion to Exclude Evidence. Paper 56 ("Opp. Ex. Ev."). On November 28, 2018, Patent Owner filed a Reply to Petitioner's Opposition to Patent Owner's Motion to Exclude Evidence. Paper 57 ("Reply Ex. Ev.>").

An oral hearing was held on December 11, 2018. A transcript of the oral hearing is included in the record. Paper 63 ("Tr.>").

*B. Related Matters*

Petitioner identifies the following as matters that the '423 Patent “is or has been involved.”

	<b>Name</b>	<b>Number</b>	<b>District</b>
1.	<i>Smart Search Concepts LLC v. Buy.com Inc.</i>	1-13-cv-01034	D. Del.
2.	<i>Smart Search Concepts LLC v. Wal-Mart Stores Inc.</i>	1-13-cv-01042	D. Del.
3.	<i>Smart Search Concepts LLC v. Neiman Marcus Inc.</i>	1-13-cv-01039	D. Del.
4.	<i>Vilox Tech. LLC v. The Priceline Group, Inc.</i>	2-15-cv-01460	E.D. Tex.
5.	<i>Vilox Tech. LLC v. Orbitz Worldwide, Inc.</i>	2-15-cv-01459	E.D. Tex.
6.	<i>Vilox Tech. LLC v. Expedia, Inc.</i>	2-15-cv-01457	E.D. Tex.
7.	<i>Vilox Tech. LLC v. Express, Inc.</i>	2-15-cv-02025	E.D. Tex.
8.	<i>Vilox Tech. LLC v. Costco Wholesale Corp.</i>	2-15-cv-02019	E.D. Tex.
9.	<i>Vilox Tech. LLC v. Mindgeek USA, Inc.</i>	2-16-cv-01278	E.D. Tex.

Pet. 1–2. Patent Owner submits that there are no related matters in accordance with 37 C.F.R. § 42.8(b)(2) — this section requires identification of “any other judicial or administrative matter that would affect, or be affected by, a decision in the proceeding.” Paper 4 (Patent Owner’s Mandatory Notices), 2.

Accordingly, we understand that (i) the judicial matters involving the '423 Patent identified by Petitioner are no longer pending and (ii) there are no other matters that would affect or be affected by a decision in this proceeding.

*C. The Challenged Patent*

The '423 patent discloses, in relevant part, formatting for display on a screen the data returned (i.e., search results) from querying a database — a database is a collection of data having a structure, such as a collection of tables for a relational database. *E.g.*, Ex. 1001, [57], 1:24–54, 24:51

(reciting for independent claim 1 “[a] computer-implemented method for displaying data”), 25:3–4 (reciting for independent claim 3 “[a] computer-implemented method for formatting data for display”). More specifically, the ’423 patent discloses that if the search results from a query would be too large (e.g., too many entries) to be displayed conveniently on a screen, the search results can be truncated so that they can be displayed more easily. *E.g., id.* at [57], 8:27–48. In one embodiment, when the search results are larger than the display size, the query’s constraints are changed so that fewer distinct search results are returned, allowing for the search results to be displayed on one page. *Id.* at 8:40–48. For example, the screen may be limited to displaying 20 lines of data, and thus, if the query returns more than 20 entries, the entries would need to be truncated (e.g., instead of a full name of a city, the first *n* letters can be used) until a displayable amount (i.e., 20 or less) of search results are achieved. *Id.* at 8:36–37, 8:48–52. Figure 10, a portion of which is shown below, illustrates an example of this truncation. *Id.* at 3:62–63.

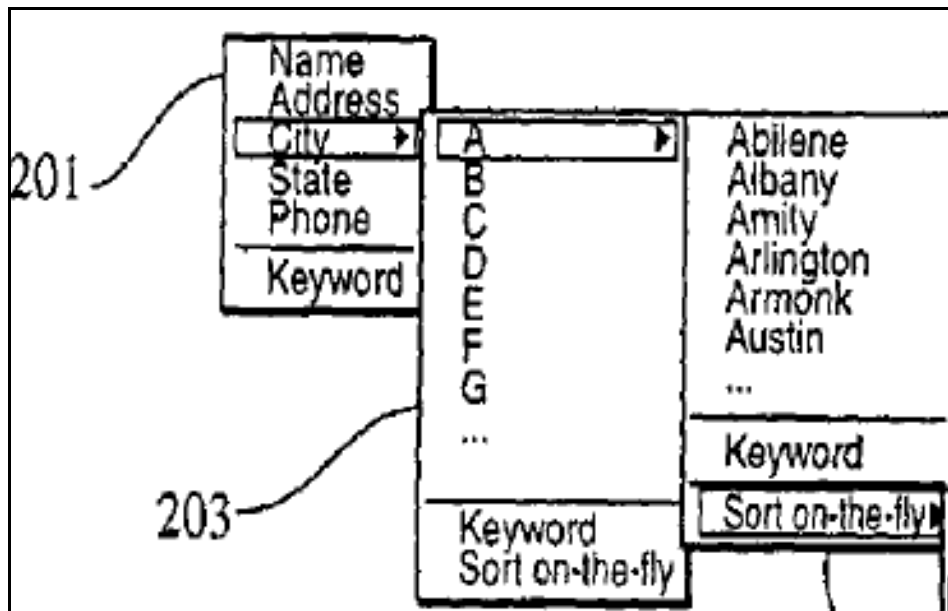

This portion of Figure 10 illustrates a graphical user interface for a database having data fields (i.e., Name, Address, City, State, and Phone) from which a user has selected the “City” data field for display. *Id.* at 11:17–27. The number of cities (i.e., entries) contained in the database is too large, however, to conveniently display on one page on the screen. *Id.* at 11:27–30. Accordingly, the city names are truncated until a convenient display is achieved — resulting in only the first letter (e.g., “A,” “B,” “C”) of the city names being displayed. *Id.* at 11:30–33, Fig. 10. This portion of Figure 10 additionally shows that the user next selected cities beginning with the letter “A,” with those results (i.e., “Abilene, Albany, . . . Austin”) being displayed. *Id.* at 11:34–35, Fig. 10.

Independent claim 14, which is not challenged, for example, is directed to this embodiment and recites “determining a first [q]uantity indicative of a number of entries of the selected data field,” “reducing a size of data to be displayed,” and “displaying data from the selected data field.” *Id.* at 26:15–18, 26:27; *see also* Ex. 1002, 215–20 (reciting claims that later issued in the parent application, including claim 1, which recites “determining a quantity of entries in the selected database field” and “if the quantity exceed[s] a specified amount, truncating data, and displaying the truncated data wherein the truncating reduces characters in one or more entries in the selected database field and the truncated data *represents* each of the entries in the selected database field”) (emphasis added).

In contrast to the above embodiment, the challenged claims are directed to determining “a number of characters” for each entry of a selected

data field, rather than the number of entries.<sup>1</sup> *E.g., id.* at 24:58–59, 25:8–9. If the number of characters exceeds a limit, the challenged claims require reducing the number of characters for *each* entry and displaying the reduced number of characters for *each* entry. *E.g., id.* at 24:60–64, 25:10–24. In other words, the challenged claims require displaying at least part of the entry for *each* entry, rather than just data that *represents* each of the entries.

#### *D. Illustrative Challenged Claim*

Petitioner challenges claims 1–9 and 13 of the '423 patent, of which claims 1 and 3 are independent claims. Claim 1 is illustrative of the claimed subject matter and is reproduced below.

1. A computer-implemented method for displaying data comprising:
  - determining a database schema for a database;
  - providing a list of database fields, wherein the list includes a descriptor indicating a data category;
  - receiving a search selection for a database field on the provided list of database fields;
  - determining a number of characters included in each entry in the selected database field; and
  - if the number of characters included in each entry exceeds a specified amount of characters, displaying a portion of each entry in the selected database field, wherein a number of characters displayed in each portion is less than or equal to the specified amount of characters; and

---

<sup>1</sup> Petitioner, in the context of Patent Owner's Motion to Amend, argues that features (e.g., displaying a truncated portion of *each entry* in the selected database field) in the amended claims, which also are recited in the challenged claims, lack written description support in the Specification. MTA Opp. 2–8. In light of our determinations below, we need not, and thus, do not reach this issue.

if the number of characters included in each entry does not exceed the specified amount, displaying each entry in its entirety.

*E. Asserted Grounds of Unpatentability*

Petitioner asserts the following grounds of unpatentability:

	<b>References</b>	<b>Basis<sup>2</sup></b>	<b>Challenged Claims</b>
1.	Maloney <sup>3</sup> and Bertram <sup>4</sup>	§ 103(a)	1–4, 7–9, and 13
2.	Excel <sup>5</sup> and Bertram	§ 103(a)	1–4, 7–9, and 13
3.	Maloney, Bertram, and Kanevsky <sup>6</sup>	§ 103(a)	5 and 6
4.	Excel, Bertram, and Kanevsky	§ 103(a)	5 and 6

Pet. 4.

III. DISCUSSION

*A. Level of Ordinary Skill in the Art*

In determining the level of ordinary skill in the art, various factors may be considered, including the “type of problems encountered in the art; prior art solutions to those problems; rapidity with which innovations are

---

<sup>2</sup> The Leahy-Smith America Invents Act (“AIA”) included revisions to 35 U.S.C. § 100 *et seq.* effective on March 16, 2013. Because the ’423 patent issued from an application filed before March 16, 2013, we apply the pre-AIA versions of the statutory bases for unpatentability.

<sup>3</sup> U.S. Patent No. 5,701,453 (issued Dec. 23, 1997) (Ex. 1006, “Maloney”).

<sup>4</sup> U.S. Patent No. 7,168,039 B2 (filed June 2, 1998 and issued Jan. 23, 2007) (Ex. 1007, “Bertram”).

<sup>5</sup> Excerpts of John Walkenbach, *Microsoft Excel 2000 Bible* (IDG Books Worldwide, Inc. 1999) (Ex. 1009, “Excel”). Petitioner submits approximately forty of Excel’s pages as Exhibit 1009. Patent Owner submits five additional pages of Excel as Exhibit 2004.

<sup>6</sup> U.S. Patent No. 6,300,947 B1 (filed July 6, 1998 and issued Oct. 9, 2001) (Ex. 1008, “Kanevsky”).



made; sophistication of the technology; and educational level of active workers in the field.” *In re GPAC, Inc.*, 57 F.3d 1573, 1579 (Fed. Cir. 1995) (citing *Custom Accessories, Inc. v. Jeffrey-Allan Indus., Inc.*, 807 F.2d 955, 962 (Fed. Cir. 1986)). “[O]ne or more factors may predominate.” *Id.*

Petitioner asserts a person having ordinary skill in the art at the time of the invention would have had “at least a bachelor’s degree in Computer Science or an equivalent field (or equivalent industry experience) and at least one year of experience designing, implementing, and using database management systems.” Pet. 6–7 (citing Ex. 1005<sup>7</sup> ¶¶ 22–25). Patent Owner’s expert, Dr. Chu, makes the same assessment of the level of skill in the art. Ex. 2017 ¶ 21.

We agree with and apply Petitioner’s definition of the level of skill in the art. *See* Ex. 1005 ¶¶ 22–24. We find that this definition is consistent with the level of ordinary skill in the art reflected by the prior art of record. *See Okajima v. Bourdeau*, 261 F.3d 1350, 1355 (Fed. Cir. 2001); *GPAC*, 57 F.3d at 1579; *In re Oelrich*, 579 F.2d 86, 91 (CCPA 1978).

### *B. Claim Construction*

We interpret claims of an unexpired patent using the “broadest reasonable construction in light of the specification of the patent in which [the claims] appear[.]” 37 C.F.R. § 42.100(b) (2017); *see Cuozzo Speed Techs., LLC v. Lee*, 136 S. Ct. 2131, 2142–46 (2016) (concluding the broadest reasonable construction “regulation represents a reasonable exercise of the rulemaking authority that Congress delegated to the Patent

---

<sup>7</sup> Here, Petitioner cites to Exhibit 1005 by paragraph number. Petitioner also cites to Exhibit 1005 by exhibit page number, on occasion. We copy the manner Petitioner cites to Exhibit 1005 for each specific citation.

Office”). Under that standard, claim terms are presumed to be given their ordinary and customary meaning as would be understood by one of ordinary skill in the art in the context of the entire disclosure. *In re Translogic Tech., Inc.*, 504 F.3d 1249, 1257 (Fed. Cir. 2007). Any special definition for a claim term must be set forth with reasonable clarity, deliberateness, and precision. *In re Paulsen*, 30 F.3d 1475, 1480 (Fed. Cir. 1994). Further, “[t]he [U.S. Patent and Trademark Office] should also consult the patent’s prosecution history in proceedings in which the patent has been brought back to the agency for a second review.” *Microsoft Corp. v. Proxyconn, Inc.*, 789 F.3d 1292, 1298 (Fed. Cir. 2015), *overruled on other grounds by Aqua Prods., Inc. v. Matal*, 872 F.3d 1290 (Fed. Cir. 2017).

Petitioner proposes constructions for two claim terms: “determining a database schema” and “truncation.” Pet 13. Patent Owner proposes constructions for those two terms, plus three additional terms: “determining a number of characters in each entry of the selected database field”; “displaying a portion of each entry in the selected database field, wherein a number of characters displayed in each portion is less than or equal to the specified amount of characters”; and “each entry from the selected data field is displayed on a terminal.” PO Resp. 27–30. We address below these five terms proposed for construction.

### *1. Determining a Database Schema*

Petitioner proposes that claim 1’s “determining a database schema” limitation should be construed as “determining a collection of tables of a database.” Pet. 13–14 (citing Ex. 1005 ¶¶ 44–45). In support of this proposed construction, Petitioner quotes the ’423 patent’s Specification and argues that a person of ordinary skill in the art would have understood a

*schema* is “a collection of tables of a database.” *Id.* at 13 (quoting Ex. 1001, 1:50–54); *see also* Ex. 1001, 1:50–54 (“All databases require a consistent structure, termed a schema, to organize and manage the information. In a relational database, the schema is a collection of tables. Similarly, for each table, there is generally one schema to which it belongs.”).

Petitioner also argues that Patent Owner incorrectly construes “‘a database’ as ‘data stored in computerized files,’” because limiting a database to “files” is contrary to the Specification and improperly excludes preferred embodiments. Pet. Reply 6–7 (citing Ex. 1001, 1:38–40, 1:51–52, 2:60–3:2) (arguing that the Specification teaches that data can be contained in a file *or a table*). Petitioner also argues that Patent Owner “does not argue against any ground of unpatentability by distinguishing a table and a file, so this construction is moot.” *Id.* at 7 n.2.

Patent Owner proposes that “determining a database schema” should be construed as “ascertaining or identifying the logical structure of data stored in computerized files.” PO Resp. 27 (citing Ex. 2017 ¶ 49). In support of this proposed construction, Patent Owner argues that a common definition for “determining” is “to fix or define the position or configuration of.” *Id.* (citing Ex. 2017 ¶ 45). Patent Owner also argues that one of ordinary skill in the art “would have understood ‘determining’ to be an active step in a process.” *Id.* As to “database,” Patent Owner argues that the Specification refers to it “as a computerized ‘collection of data.’” *Id.* (citing Ex. 1001, 1:24–25). As to “schema,” Patent Owner relies on a dictionary definition which “refers to ‘schema’ as ‘a description of the logical structure of a database.’” *Id.* (citing Ex. 2017 ¶ 47). Patent Owner argues that Petitioner’s construction as to “schema” is too limiting because, although the

'423 patent “refers to ‘schema’ in a relational database as ‘a collection of tables,’ other database types would have other structures.” *Id.*

We have reviewed the parties’ arguments and supporting evidence, as well as the claim language and the ’423 patent’s Specification. We parse through the parties’ arguments below.

Patent Owner relies on its expert, Dr. Chu, to replace “determining” with “ascertaining or identifying” in its proposed construction. *See* PO Resp. 27; Ex. 2017 ¶ 45. Dr. Chu appears to piece this construction together by (i) agreeing with Petitioner’s expert, Dr. Greenspun, that the ’423 patent refers to “identifying” (rather than “determining”) a database schema and (ii) opining that “[a] common definition for ‘identifying’ is ‘to ascertain the origin, nature, or characteristics of.’” Ex. 2017 ¶ 45. Dr. Chu opines that one of ordinary skill in the art “would have understood ‘determining’” to mean “ascertaining the components of.” *Id.* Dr. Chu further opines that one of ordinary skill in the art would have understood “determining” means “ascertaining or identifying,” in the context of “determining a database schema.” *Id.* ¶¶ 45, 49. Dr. Chu, however, fails to identify factual support for why “determining” should be replaced with “ascertaining or identifying.” *Id.* Accordingly, we find that the above cited testimony of Dr. Chu is entitled to little or no weight because it is conclusory and lacks factual support. *See In re Am. Acad. of Sci. Tech Ctr.*, 367 F.3d 1359, 1368 (Fed. Cir. 2004) (“[T]he Board is entitled to weigh the declarations and conclude that the lack of factual corroboration warrants discounting the opinions expressed in the declarations.”); 37 C.F.R § 42.65(a). Moreover, Patent Owner admits that determining, ascertaining, and identifying are synonyms for each other. Tr. 36:3–9. Thus, Patent Owner does not explain how

replacing “determining” with “ascertaining or identifying” is relevant to the patentability issues in this case.

Patent Owner also relies on Dr. Chu’s testimony to argue that one of ordinary skill in the art “would have understood ‘determining’ to be an active step in a process.” PO Resp. 27 (citing Ex. 2017 ¶ 45). Patent Owner’s Response and Dr. Chu do not explain, however, the meaning of “active step,” its interplay with Patent Owner’s proposed construction, or any factual basis for requiring an “active step.” *Id.*; Ex. 2017 ¶ 45.

As best we determine from Patent Owner’s statements during the oral hearing, Patent Owner’s “active step” requires a computer process, such as a “search engine in the search on the fly search engine program [to] . . . look at a database and . . . identify . . . what the schema is . . . every time it accesses the database.” Tr. 35:19–36:2. That explanation of what an “active step” constitutes, however, is not in either Patent Owner’s Response or in Dr. Chu’s Declaration, and therefore, we need not consider such a late argument. Even considering Patent Owner’s explanation made during the oral hearing, along with the arguments made in Patent Owner’s Response, we are not persuaded by the argument that the disputed phrase requires an “active step.” Neither Patent Owner nor Dr. Chu points to any intrinsic evidence or other documentary evidence to support the argument that determining requires an “active step.” *See In re Geisler*, 116 F.3d 1465, 1470 (Fed. Cir. 1997) (explaining that attorney arguments and conclusory statements that are unsupported by factual evidence are entitled to little probative value). Moreover, Patent Owner does not provide a principled basis for importing an “active step” into this limitation based on the Specification. *See Superguide Corp. v. DirecTV Enterprises, Inc.*, 358 F.3d

870, 875 (Fed. Cir. 2004) (“[I]t is important not to import into a claim limitations that are not a part of the claim.”).

As to “database,” Patent Owner argues that the Specification refers to it “as a computerized ‘collection of data,’” yet Patent Owner proposes construing “database” as “data stored in computerized files.” PO Resp. 27 (citing Ex. 1001, 1:24–25). Moreover, Patent Owner’s proposed construction conflicts with Patent Owner’s expert’s opinion of what “database” means — Dr. Chu opines that “database” means “a computerized collection of data.” Ex. 2017 ¶ 46. As Petitioner argues, and in accordance with Dr. Chu’s opinion, we find that there is no basis to limit a “database” to “files,” as such is contrary to the Specification. Ex. 1001, 124–25, 1:38–40, 1:51–52, 2:60–3:2.

As to “schema,” we agree with Patent Owner that Petitioner’s proposed construction is too narrow as it limits “schema” to a relational database’s structure (i.e., tables), despite the Specification’s teaching of additional database types. *See, e.g.*, Ex. 1001, 1:25–26, 1:29–30 (“Various architectures have been devised to organize data in a computerized database. . . . Three main database architectures are termed hierarchical, network and relational.”), 1:51–52 (“In a relational database, the schema is a collection of tables.”). Patent Owner’s proposed construction also is too limiting in that the Specification refers to a “schema” as “consistent structure” without limiting “schema” to a “logical structure.” Ex. 1001, 1:50–51 (“All databases require a consistent structure, termed a schema, to organize and manage the information.”).

In summary, we find no principled basis to replace “determining” with “ascertaining or identifying,” or to require Patent Owner’s “active

step.” Nor do we find a principled basis to limit “database schema” as the parties propose. Accordingly, we do not adopt either of the parties’ proposed constructions.

Having considered the evidence presented, we conclude that no further express claim construction of this limitation is necessary to resolve the issues presented in this trial. *See Vivid Techs., Inc. v. Am. Sci. & Eng’g, Inc.*, 200 F.3d 795, 803 (Fed. Cir. 1999) (“[O]nly those terms need be construed that are in controversy, and only to the extent necessary to resolve the controversy.”).

## 2. Truncation

Petitioner relies on a dictionary definition to propose that we construe “truncation” to mean “[t]he deletion or omission of a leading or of a trailing portion of a string in accordance with specified criteria.” Pet. 13 (citing Ex. 1010, 3). Petitioner argues that this definition is consistent with an example from the Specification where truncation was employed. *Id.* (citing Ex. 1001, 8:27–9:2). Petitioner also argues that one of ordinary skill in the art would have understood its proposed construction to be the broadest reasonable interpretation of “truncation.” *Id.* (citing Ex. 1005 ¶¶39–43; Ex. 1003, 174).

Patent Owner argues that Petitioner’s proposed construction for “truncation” is incorrect, as it conflicts with the definition the applicant provided during the prosecution of the ’423 patent’s parent application. PO Resp. 28–29. In particular, Patent Owner points to the definition provided during that prosecution, which defines “truncation” as: “[T]o cut off the beginning or end of [a] series of characters; specifically[,] to eliminate one or more of the least significant (typically rightmost) digits.” *Id.* (quoting Ex.

1005 ¶ 41 (quoting Ex. 1003, 174)) (emphasis omitted); *see also* Ex. 1005 ¶ 41.

The fact that a term “has multiple dictionary meanings does not mean that all of these meanings are reasonable interpretations in light of” the intrinsic evidence. *See PPC Broadband, Inc. v. Corning Optical Commc’ns RF, LLC*, 815 F.3d 747, 752 (Fed. Circ. 2016). To that end, statements made during prosecution are relevant to claim construction, and can serve to define, explain, or disavow claim scope. *See Teva Pharm. USA, Inc. v. Sandoz, Inc.*, 789 F.3d 1335, 1343 (Fed. Cir. 2015) (citations omitted). This includes “statement[s] made during prosecution of related patents[, which also] may be properly considered in construing a term common to those patents.” *Id.* Based on the statements made, and the definition offered (Ex. 1003, 174), during prosecution of the ’423 patent’s parent application, we find persuasive Patent Owner’s interpretation that “truncation” means: “To cut off the beginning or end of a series of characters; specifically, to eliminate one or more of the least significant (typically rightmost) digits.”

### *3. Remaining Terms Proposed by Patent Owner*

Patent Owner proposes three additional terms for construction: (i) “determining a number of characters in each entry of the selected database field”; (ii) “displaying a portion of each entry in the selected database field, wherein a number of characters displayed in each portion is less than or equal to the specified amount of characters”; and (iii) “wherein each entry from the selected data field is displayed on a terminal.” PO Resp. 27–30 (emphasis omitted).

First, Patent Owner argues that we should construe “determining a number of characters in each entry of the selected database field,” to mean



“determining how many characters exist in every entry of a selected database field.” *Id.* at 28.

Second, Patent Owner argues that we should construe “displaying a portion of each entry in the selected database field, wherein a number of characters displayed in each portion is less than or equal to the specified amount of characters” as follows: (i) “displaying a portion” to mean “a portion of an entry that had been reduced by truncation,” and (ii) “wherein a number of characters displayed in each portion is less than or equal to the specified amount of characters” to mean “a displayed portion is a part of an entry truncated to reduce a number of characters in the entry.” *Id.* at 29 (citing Ex. 2017 ¶ 57).

Third, Patent Owner argues that we should construe “wherein each entry from the selected data field is displayed on a terminal” to mean “all entries from the selected data field are displayed on a terminal.” *Id.* at 30 (citing Ex. 2017 ¶ 58).

Petitioner argues that Patent Owner “does not argue that these constructions affect patentability,” and more specifically, that Patent Owner’s proposed constructions do not “affect the obviousness of the claims.” Pet. Reply 8.

We agree with Petitioner that Patent Owner’s proposed constructions do not differ from the claim language in a way meaningful to the obviousness analysis. Rather, Patent Owner relies on its expert, Dr. Chu, to reword the claim language, without adding clarity to the claim language or providing reasoning to do so. PO Resp. 27, 29–30. For example, Patent Owner replaces “each” with “every” for the first term and replaces “each”

with “all” in the third term without explaining any difference in meaning between any of the terms. *Id.*

Having considered the evidence presented, we conclude that no express claim construction of these limitations is necessary to resolve the issues presented in this trial. *See Vivid Techs.*, 200 F.3d at 803.

### *C. Conditional Limitations*

Independent claims 1 and 3 are method claims that recite conditional steps (i.e., steps that are performed only if certain conditions precedent are met). Our precedential decision in *Ex parte Schulhauser*, No. 2013-007847, 2016 WL 6277792 (PTAB Apr. 28, 2016) (precedential), thus applies to these claims. We address below *Schulhauser*'s application, as well as Patent Owner's arguments that attempt to distinguish *Schulhauser*.

#### *1. Claim 1*

The last two elements of claim 1 are conditional steps. These two steps are:

*if the number of characters included in each entry exceeds a specified amount of characters, displaying a portion of each entry in the selected database field, wherein a number of characters displayed in each portion is less than or equal to the specified amount of characters; and*

*if the number of characters included in each entry does not exceed the specified amount, displaying each entry in its entirety.*

Ex. 1001, 24:60–67 (emphasis added to the conditions).

As set forth in *Schulhauser*, a method claim that includes a conditional step can be thought of as covering two methods — one method where the condition for the step is met and the step is performed, and the second method where the condition is *not* met and the step is *not* performed. *See Schulhauser*, 2016 WL 6277792, at \*4. The broadest reasonable

interpretation of such a claim encompasses the method where only the non-conditional steps are performed (i.e., this occurs when the condition is *not* met). *See id.* at \*3–4. Furthermore, *Schulhauser* determines that if a method’s conditional step does not need to be performed, it does not need to be shown to invalidate the method claim. *Id.* at \*4.

Such a determination follows from the relationship between invalidity and infringement. “[I]t is axiomatic that that which would literally infringe if later anticipates if earlier.” *Bristol-Myers Squibb Co. v. Ben Venue Labs, Inc.*, 246 F.3d 1368, 1378 (Fed. Cir. 2001). As to infringement, conditional method steps need not be performed for infringement to be found. *See, e.g., Applera Corp. v. Illumina, Inc.*, 375 F. App’x 12, 21 (Fed. Cir. 2010) (nonprecedential) (affirming a district court’s interpretation of a method claim as including a step that need not be practiced if the condition for practicing the step is not met); *Cybersettle, Inc. v. Nat’l Arbitration Forum, Inc.*, 243 F. App’x 603, 607 (Fed. Cir. 2007) (nonprecedential) (“It is of course true that method steps may be contingent. If the condition for performing a contingent step is not satisfied, the performance recited by the step need not be carried out in order for the claimed method to be performed.”). Likewise, as to unpatentability, conditional method steps that need not be performed, also need not be shown in establishing unpatentability. *Schulhauser*, 2016 WL 6277792, at \*4–5.

Here, claim 1’s conditional steps are mutually exclusive and together the conditions cover the full set of possibilities for the condition (i.e., “if . . . exceeds a specified amount” and “if . . . does not exceed the specified amount”). Thus, the broadest reasonable interpretation of claim 1 encompasses a method where one, and only one, of the conditional steps is

performed and the other conditional step is not performed. *Id.* at \*3–4. Although Petitioner contends that the combination of Maloney and Bertram teaches both of claim 1’s conditional steps, only one of these steps needs to be shown for unpatentability.

Patent Owner argues that applying *Schulhauser* here is unreasonable based on a nonprecedential Board decision, i.e., *Ex parte Gopalan*, Appeal 2017-007009, (PTAB May 21, 2018). More specifically, Patent Owner argues that *Gopalan* found all of the conditional limitations limiting (i.e., needing to be shown for unpatentability) because that is how one of ordinary skill in the art, in light of *Gopalan*’s specification, “would reasonably be expected to interpret the claim.” PO Resp. 32–33 (citing *Gopalan*, slip op. at 5–6). In other words, *Gopalan* “found the notion of the two steps ‘work[ing] together’ in *Gopalan*’s specification,” according to Patent Owner. *Id.* at 33 (citing *Gopalan*, slip op. at 5–6).

Patent Owner’s reliance on *Gopalan* is unavailing. *Gopalan* is nonprecedential and, in any case, was decided on different facts than this case. Moreover, “[i]n claim construction, ‘the name of the game is the claim.’ . . . Based on the claim limitations as written, the broadest reasonable interpretation of claim 1 encompasses an instance in which the method ends” without the first condition (i.e., “if the number of characters included in each entry exceeds a specified amount of characters”) ever having been met. *See Schulhauser*, 2016 WL 6277792, at \*4 (citations omitted); Ex. 1001, 24:51–67 (reciting claim 1). For example, when each of the entries (e.g., cat, dog, bird, and fish) in a selected data field (e.g., pet) do not exceed a specified amount (e.g., 5 characters), the first condition is never

met, and each of the entries is displayed in its entirety, in accordance with claim 1. Ex. 1001, 24:51–67.

Furthermore, we find that there is nothing in the Specification that would have led one of ordinary skill in the art to have understood that all of claim 1’s steps are required (i) to display data on a terminal, or (ii) to display data from “each entry from the selected database field,” as Patent Owner argues. PO Resp. 33–34; *see, e.g.*, Ex. 1001, Figs. 18–21, 15:52–16:35. Patent Owner’s attorney argument is conclusory, not supported by record evidence, and, therefore, is not persuasive. *See In re Geisler*, 116 F.3d 1465, 1470 (Fed. Cir. 1997) (explaining that attorney arguments and conclusory statements that are unsupported by factual evidence are entitled to little probative value).

In summary, under *Schulhauser*’s precedential reasoning, the broadest reasonable interpretation of claim 1 encompasses a method where one, and only one, of the conditional steps is performed and the other conditional step is not performed. *Schulhauser*, 2016 WL 6277792, at \*3–4; *see supra*.

## 2. Claim 3

The last limitation of claim 3 is a conditional step. This conditional step is:

*if the first quantity exceeds a specified limit*, reducing a number of characters to be displayed for each entry from the selected data field, comprising:

performing a truncation that reduces the number of characters to be displayed from the selected data fi[el]d,  
comparing the reduced number of characters to the specified limit, and

if the reduced number of characters exceeds the specified limit,<sup>8</sup> repeating the truncation and comparing steps until the reduced number of characters to be displayed from the selected data field is less than or equal to the specified limits; and

displaying the reduced number of characters for each entry from the selected data field.

Ex. 1001, 25:10–24 (emphasis added to the condition).

As discussed above, the broadest reasonable interpretation of a method claim that includes one conditional step encompasses where only the non-conditional steps are performed (i.e., the method when the condition is *not* met). *See Schulhauser*, 2016 WL 6277792, at \*3–4. Nor do we find anything in the Specification that would contradict this broadest reasonable interpretation of claim 3. *See, e.g.*, Ex. 1001, Figs. 18–21, 15:52–16:35.

In addition, as we discussed above (*supra* Section III(C)(1)), Patent Owner’s reliance on the Board’s non-precedential *Gopalan* decision is unavailing. Likewise, we are not persuaded by Patent Owner’s attorney argument that one of ordinary skill in the art “would understand that the construction of claim 3 that removes any steps directed to displaying formatted data in a claim that is expressly directed to ‘formatting data for display’ would render the claim meaningless.” *See* PO Resp. 35; *In re Geisler*, 116 F.3d at 1470.

Accordingly, under *Schulhauser*, Petitioner does not need to show claim 3’s conditional step to show unpatentability.

---

<sup>8</sup> This embedded conditional step is not reached if the first condition of the limitation (i.e., if the first quantity exceeds a specified limit) is not met.

*D. Law for Demonstrating Obviousness*

To prevail in challenging Patent Owner’s claims, Petitioner must demonstrate by a preponderance of the evidence that the claims are unpatentable. 35 U.S.C. § 316(e); 37 C.F.R. § 42.1(d). “In an [*inter partes* review], the petitioner has the burden from the onset to show with particularity why the patent it challenges is unpatentable.” *Harmonic Inc. v. Avid Tech., Inc.*, 815 F.3d 1356, 1363 (Fed. Cir. 2016) (citing 35 U.S.C. § 312(a)(3) (requiring *inter partes* review petitions to identify “with particularity . . . the evidence that supports the grounds for the challenge to each claim”)). This burden of persuasion never shifts to Patent Owner. *See Dynamic Drinkware, LLC v. Nat’l Graphics, Inc.*, 800 F.3d 1375, 1378 (Fed. Cir. 2015) (citing *Tech. Licensing Corp. v. Videotek, Inc.*, 545 F.3d 1316, 1326–27 (Fed. Cir. 2008)) (discussing the burden of proof in *inter partes* review).

A claim is unpatentable under 35 U.S.C. § 103(a) if the differences between the claimed subject matter and the prior art are such that the subject matter, as a whole, would have been obvious at the time of the invention to a person having ordinary skill in the art. *KSR Int’l Co. v. Teleflex, Inc.*, 550 U.S. 398, 406 (2007). The question of obviousness is resolved on the basis of underlying factual determinations including: (1) the scope and content of the prior art; (2) any differences between the claimed subject matter and the prior art; (3) the level of ordinary skill in the art; and (4) objective evidence

of non-obviousness, if present.<sup>9</sup> *Graham v. John Deere Co.*, 383 U.S. 1, 17–18 (1966).

#### IV. OBVIOUSNESS OVER MALONEY AND BERTRAM

Petitioner argues claims 1–4, 7–9, and 13 of the '423 patent are unpatentable under 35 U.S.C. § 103(a) as being obvious over the combination of Maloney and Bertram. Pet. 4, 14–45; Pet. Reply 16–25. Patent Owner argues that (i) the combination of Maloney and Bertram fails to teach all of the elements of claims 1 and 2, and (ii) one of ordinary skill in the art would not have combined Maloney's and Bertram's relevant teachings. PO Resp. 46–57.

We have reviewed the parties' arguments and the evidence of record. For the reasons that follow, we determine that Petitioner has shown by a preponderance of the evidence that claims 1–4, 7–9, and 13 would have been obvious over the combination of Maloney and Bertram.

##### *A. Summary of Maloney*

Maloney discloses a graphical user interface that allows an end user to retrieve data from a database without knowing the database's structure. Ex. 1006, [57], 4:64–5:5. To account for this lack of end user knowledge, Maloney provides a list of pre-existing *logical schemas* from which the end user selects. *Id.* at [57], 4:64–5:5. Each logical schema is created beforehand by a person who knows the database's physical structure (e.g., a database administrator (“DBA”)), and who selects relevant tables from the database and identifies the logical relationship (e.g., a common field)

---

<sup>9</sup> Patent Owner does not present arguments or evidence of such objective evidence of non-obviousness in its Response. *See generally* PO Resp. 46–57, 67–69.



between the selected tables. *Id.* at 2:60–67, 7:44–56. Accordingly, using a logical schema, an end user can access and manipulate data from the database without knowing the database’s structure. *Id.* at 4:64–5:5. Figure 19, shown below, illustrates a form created by an end user using a selected logical schema. *Id.* at 3:56–57.

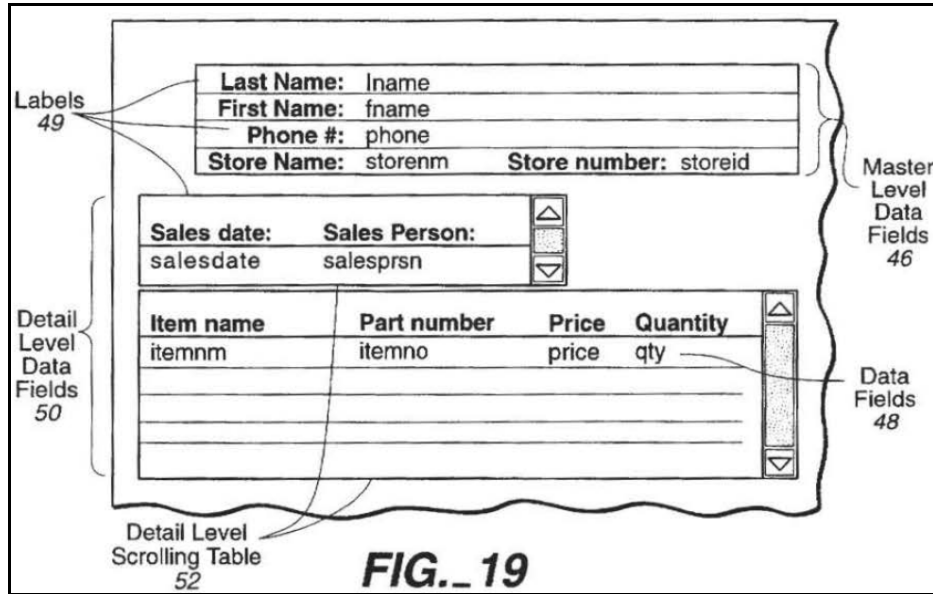

Figure 19 shows a form created by an end user using the “invoice” logical schema. *Id.* at 17:58–59, Fig. 19. In creating the form, the end user customized the arrangement of data returned from the database. *Id.* at 17:59–60. Figure 19 shows the end user selected (i) the lname, fname, phone, storenm, and storeid data fields to be displayed in the “Master Level” portion of the form, and (ii) the salesdate, salesprsn, itemnm, itemno, price, and qty data fields to be displayed in the “Detail Level” portion of the form — the Master and Detail Levels reflect a one-to-many relationship. *Id.* at 17:62–18:5, Fig. 19. Furthermore, “[e]ach data field is preceded by text [(i.e., “Labels”)] describing the field created by the end user when designing the form.” *Id.* at 17:65–66.

After the end user has created the form, the end user can query the database based on the data fields in the form to retrieve and display the data for those fields. *Id.* at 18:13–17. The database management system determines from the logical schema the physical tables on which to perform the query, as well as how the physical tables are related. *Id.* at 18:17–22.

*B. Summary of Bertram*

Bertram discloses reducing the amount of horizontal space required for displaying text data (e.g., column headings or entries) in a column on a display screen. Ex. 1007, [57]. To this end, Bertram discloses abbreviating, and potentially also truncating, the data for display so that it complies with a set width limit. *Id.* at Figs. 3, 7, 5:10–11, 7:25–32, 7:55–8:65. Figure 7, shown below, illustrates a flow chart for an embodiment in accordance with Bertram's teachings. *Id.* at 3:25–27.

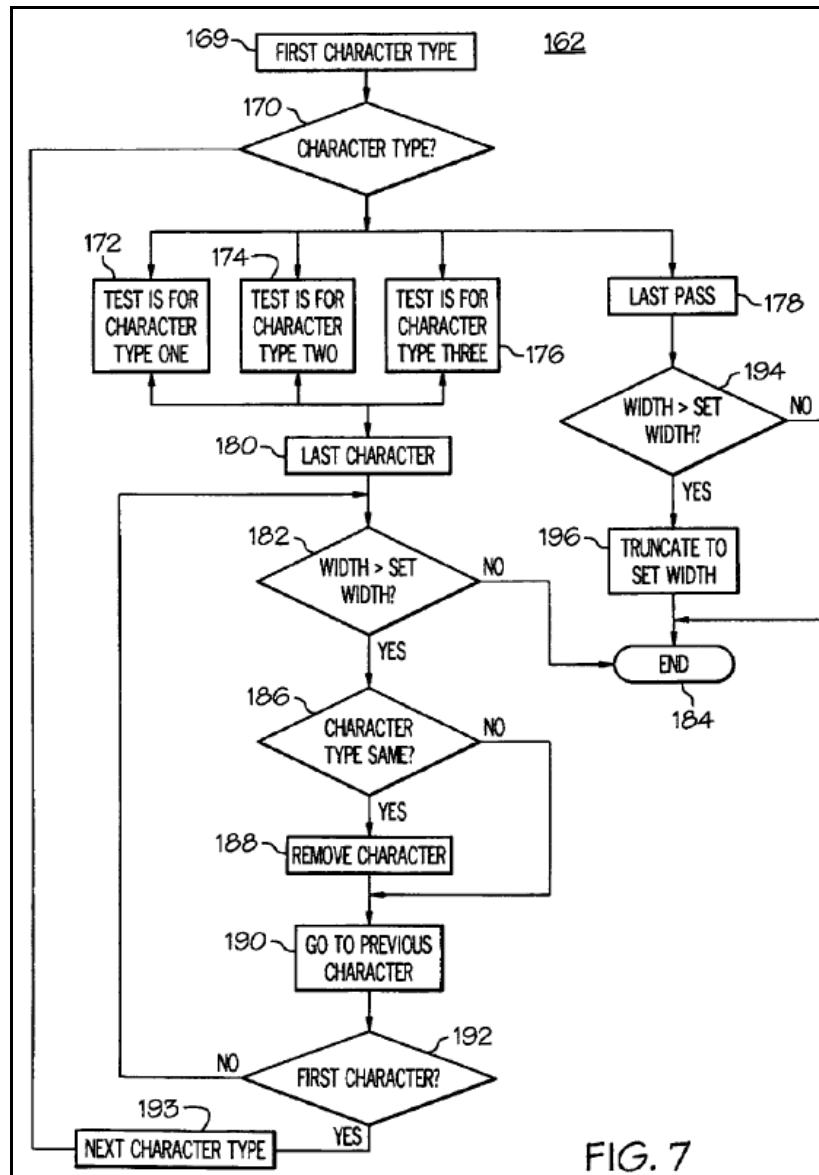

Figure 7 illustrates a flow chart depicting a method for abbreviating and truncating column headings and entries for display. *Id.* at 3:25–27, 6:24–37 (disclosing abbreviating entries), 7:25–32 (disclosing that Bertram’s teachings can be applied to entries, as well as column headings). This method relies on a hierarchy of character types (e.g., spaces (type one), lower case vowels (type two), lower case consonants (type three)) for removing characters from the entry if the entry exceeds the set width. *Id.* at 7:55–67. If an entry is too wide — width checked at step 182 (“WIDTH >

SET WIDTH?”) — the entry is abbreviated by first removing spaces, then lower case vowels, and then lower case consonants, in successive passes, until the entry no longer exceeds the set width. *Id.* at 8:3–57. If after the character types have been processed, and the entry still is too wide — width checked at step 194 (“WIDTH > SET WIDTH?”) — the entry “is truncated to the appropriate number of characters.” *Id.* at 8:58–65, Fig. 7; *see also id.* at 5:10–11 (“truncat[ing] the columns to be five characters in width”).

### *C. Independent Claim 1*

#### *1. Preamble*

The preamble of claim 1 is “[a] computer-implemented method for displaying data.” Ex. 1001, 24:51–52. The parties do not address whether the preamble is limiting, although Petitioner does provide argument and detailed citations showing that the preamble is taught by Maloney. Pet. 17 (citing Ex. 1006, 4:5–20, 20:4–6; Ex. 1005, 29–30). Patent Owner does not dispute this showing.

Maloney teaches a “computer-implemented method for providing a hierarchical view of data stored in a plurality of relational database tables.” Ex. 1006, 4:5–20, 20:4–6; *see also* Pet. 17.

Based on the disclosures from Maloney, we find that Maloney teaches a computer-implemented method for displaying data. As we find that Maloney teaches the preamble, we need not determine whether the preamble is limiting.

#### *2. Determining a database schema*

Claim 1 recites “determining a database schema for a database.” Ex. 1001, 24:53. We agree with Petitioner that Maloney teaches this limitation. *See* Pet. 18. Maloney teaches “[p]airs of tables which will

comprise a logical schema are selected from the relational database and the logical relationships between the pairs of tables are defined.” Ex. 1006, 2:60–63; *see also* Ex. 1006, 2:58–67; Pet. 18. In other words, Maloney teaches a DBA selects relevant tables and establishes a logical relationship between the tables to create a logical schema, which teaches “determining a database schema for a database,” i.e., selecting the tables and how to relate them teaches determining a database schema. Ex. 1006, 2:58–67, 5:23–30, 8:43–48. In addition, Maloney teaches providing a list of logical schemas for a database from which the end user selects a particular logical schema (e.g., the invoice logical schema) to use. *Id.* at 17:13–27; *see also* Pet. 18. This disclosure for Maloney alternatively teaches “determining a schema for a database,” i.e., a user determines which database schema to use.

In addition, Dr. Greenspun testified that “[c]reation of each of Maloney’s logical schemas is an example of ‘determining a database schema for a database.’ Moreover, providing a list of available tables to the user who is adding tables to the logical schema is also an example of ‘determining a database schema for a database.’” Ex. 1005, 30–31 (citing Ex. 1006, 2:58–67, 8:43–48, 17:13–18); *see also* Ex. 2015, 78–79.

We disagree with Patent Owner that characterizing Maloney’s logical schemas as “sets of rules” precludes finding that Maloney teaches “determining a schema for a database.” *See* PO Resp. 51 (citing Ex. 1006, 4:45–59). Maloney disclosing that a logical schema can be thought of as “a set of rules” does not change that Maloney also teaches that a logical schema logically defines a database structure. *E.g.*, Ex. 1006, 2:60–63; *see also id.* at 4:45–59. For example, Maloney teaches that “[p]airs of tables which will comprise a logical schema are selected from [a] relational database and the

logical relationships between the pairs of tables are defined.” *E.g.*, Ex. 1006, 2:60–63. In addition, we did not construe “schema” to mean “a collection of tables,” and thus, Patent Owner’s argument predicated on such a construction is inapposite. *See supra* Section III(B)(1).

We also disagree with Patent Owner’s argument that having a DBA, who knows the physical database’s schema, create *logical schemas* fails to teach the claimed “determining a database schema.” PO Resp. 52. This argument is akin to Patent Owner’s “active step” requirement, which we rejected in construing this term. *See supra* Section III(B)(1). Simply put, a DBA having knowledge of a database’s physical structure does not preclude the DBA from “determining a database schema” by creating a logical schema.

Lastly, we find that Dr. Chu’s testimony of what one of ordinary skill in the art would have understood Maloney to teach as to this limitation is entitled to little or no weight because Dr. Chu does not provide a factual basis for his conclusions with cites to documentary evidence. *See* Ex. 2017 ¶ 130; *In re Am. Acad. of Sci. Tech Ctr.*, 367 F.3d 1359, 1368 (Fed. Cir. 2004) (“[T]he Board is entitled to weigh the declarations and conclude that the lack of factual corroboration warrants discounting the opinions expressed in the declarations.”); 37 C.F.R. § 42.65(a) (“Expert testimony that does not disclose the underlying facts or data on which the opinion is based is entitled to little or no weight.”).

Based on the disclosures from Maloney and Dr. Greenspun’s testimony, we find that Maloney teaches “determining a database schema for a database.”

### *3. Providing a list of database fields*

Claim 1 also recites “providing a list of database fields, wherein the list includes a descriptor indicating a data category.” Ex. 1001, 24:54–55. We agree with Petitioner that Maloney teaches this limitation. *See* Pet. 18–19. In particular, Maloney teaches dialog boxes, where each of the fields is listed and has a name, e.g., “storeid” with a text descriptor indicating a data category, e.g., “Store number.” Ex. 1006, 17:18–27, 17:58–18:12, Figs. 18–20; Ex. 1005, 31–35; *see also* Ex. 1006, 17:58–18:12 (disclosing “lname, fname, phone, storenm, and storeid, are pasted individually into the top portion of the form window as individual data fields 48” and that “[e]ach data field is preceded by text 49 describing the field created by the end user when designing the form”).

In addition, Dr. Greenspun testified that Maloney teaches the limitation. *See* Ex. 1005, 31–35. For example, he testified that Maloney’s Figures 18–20 illustrate lists of fields having displayed names, which teach “providing a list of database fields, wherein the list includes a descriptor indicating a data category.” *Id.* at 35 (citing Ex. 1006, Figs. 18–20). We credit Dr. Greenspun’s testimony as it is consistent with Maloney’s disclosure discussed above.

Based on the disclosures from Maloney and Dr. Greenspun’s testimony, we find that Maloney teaches “providing a list of database fields, wherein the list includes a descriptor indicating a data category.”

### *4. Receiving a search selection*

Claim 1 also recites “receiving a search selection for a database field on the provided list of database fields.” Ex. 1001, 24:56–57. We agree with Petitioner that Maloney teaches this limitation. *See* Pet. 19–20. Maloney

teaches that “[a]fter the end user has created a form or report by selecting fields, records from the database can be retrieved and viewed in the form the end user created by entering a command for the [database management system] to query the database based on the fields in the form.” Ex. 1006, 18:12–17; *see also id.* at Figs. 19–20. Dr. Greenspun’s testimony is consistent with Maloney’s disclosure discussed above. *See* Ex. 1005, 35–36.

Based on the disclosures from Maloney and Dr. Greenspun’s testimony, we find that Maloney teaches “receiving a search selection for a database field on the provided list of database fields.”

#### *5. Determining a number of characters*

Claim 1 also recites “determining a number of characters included in each entry in the selected database field.” Ex. 1001, 24:58–59. We agree with Petitioner that the combination of Maloney and Bertram teaches this limitation. *See* Pet. 20–23. As to Maloney, it teaches retrieving records (i.e., the entries in the selected database fields) for display from querying a database. Ex. 1006, 18:23–43, Fig. 20; *see also id.* at 18:24–25 (“[A] record is a row of data values obtained from a table”); *see also* Pet. 20–21 (citing Ex. 1006, Fig. 20, 18:23–43).

As to Bertram, it teaches abbreviating each of the entries in one or more columns (i.e., selected database fields) of a table for display on a screen. *E.g.*, Ex. 1007, 6:24–37 (teaching abbreviating a plurality of entries of a column), 6:38–54, 7:25–32 (applying teachings to abbreviating entries, as well as column headings). Figure 7 teaches an example method that can be used for abbreviating each entry, applied one entry at a time for a plurality of entries in a column. *Id.* at 6:24–54, 7:25–32, Fig. 7; *see also* Pet. 22; Pet. Reply 24. As part of this method, the width of the entry is



determined by comparing the entry's width to a set width, i.e., "WIDTH > SET WIDTH?" *E.g.*, Ex. 1007, Fig. 7 (steps 182 and 194), 6:24–54, 7:25–32, 8:22–29, 8:60–64. Bertram teaches repeatedly that "width" is measured in number of characters. Ex. 1007, 5:10–11 ("truncat[ing] the columns to be five characters in width"); 8:62–63 ("If the width is greater, then the column heading is truncated to the appropriate number of characters."), 9:5–8. Thus, determining the width teaches determining the number of characters. *E.g.*, *id.* at Fig. 7, 5:10–11, 6:24–54, 7:25–32, 8:58–65.

We disagree with Patent Owner's argument that one of ordinary skill in the art "would have concluded that there is no support in *Bertram* for" determining a number of characters. PO Resp. 53–54 (citing Ex. 2017 ¶¶ 131–134). Again, Bertram teaches determining whether text-based entries are too wide, and describes *width* in terms of number of characters (e.g., "five characters in width"). *E.g.*, Ex. 1007, Fig. 7, 5:10–11, 6:24–37, 8:22–29, 8:58–65. We also find that Dr. Chu's testimony of what one of ordinary skill in the art would have understood Bertram to teach as to this limitation is entitled to little or no weight because Dr. Chu does not provide a factual basis for his conclusions. *See* Ex. 2017 ¶¶ 133–134; 37 C.F.R. § 42.65(a). For example, Dr. Chu testified that he disagrees with Dr. Greenspun that Bertram counts the total number of characters against a set width. Ex. 2017 ¶ 133 (quoting Ex. 2015, 97–98, 101). Dr. Chu goes on to conclude that Bertram does not disclose or suggest "determining a number of characters in an entry." *Id.* ¶¶ 133–134. Other than disagreeing with Dr. Greenspun's deposition testimony, Dr. Chu does not explain why Bertram's description of determining whether text-based entries are too wide, where width is described in terms of characters, fails to meet "determining a

number of characters included in each entry in the selected database field.”  
*Id.* Merely stating disagreement with an opposing expert, without further explanation supported by record evidence, is not helpful to the triers of fact and is entitled to little or no weight.

We also disagree with Patent Owner that “Dr. Greenspun admitted that *Bertram* contains no explicit teaching [of] ‘determining the number of characters.’” PO Resp. 53–54 (citing Ex. 2015, 101:5–23). Rather, Dr. Greenspun merely acknowledged that particular phrases do not appear verbatim in *Bertram*. *See* Ex. 2015, 101:5–15 (responding “No, not that I’m aware of,” when asked “Are there any words anywhere in *Bertram* that say ‘enter a number of characters’?”), 101:17–23 (responding “I don’t think that *Bertram* uses that phrase, ‘determining a number of characters,’ no,” when asked “Is there any disclosure in *Bertram* that states ‘determining a number of characters’?”). There is no requirement, however, in an obviousness analysis for the prior art to “contain a description of the subject matter of the [challenged] claim in *ipsissimis verbis*.” *Cf. In re May*, 574 F.2d 1082, 1090 (CCPA 1978).

Based on the disclosures from Maloney and *Bertram*, we find that the combination of Maloney and *Bertram* teaches “determining a number of characters included in each entry in the selected database field.”

*6. If the number of characters exceeds*

Claim 1 also recites “*if the number of characters included in each entry exceeds a specified amount of characters*, displaying a portion of each entry in the selected database field, wherein a number of characters displayed in each portion is less than or equal to the specified amount of characters.” Ex. 1001, 24:60–64 (emphasis added to the condition). As we

discuss above, this is a conditional step, which does not need to be shown in finding unpatentability. *See supra* Section III(C)(1). Nonetheless, we now address this limitation as it pertains to our discussion below of Patent Owner’s Motion to Amend.

We agree with Petitioner that the combination of Maloney and Bertram teaches this limitation. *See* Pet. 23–25. As discussed above, Maloney teaches retrieving records (i.e., the entries in the selected database fields) for display from a database. Ex. 1006, 18:23–43, Fig. 20. In addition, Bertram teaches that for each entry, if the width (i.e., the number of characters) exceeds a “set width” (i.e., a specified amount of characters), removing characters until the entry’s width is equal to or less than the set width, and displaying the shortened entries (i.e., displaying a portion of each entry in the selected database field). *See, e.g.*, Ex. 1007, Fig. 7, 6:24–54, 7:25–32, 8:22–57.

In addition, Dr. Greenspun testified that “*Maloney’s* display of entries for a selected database field in view of *Bertram’s* technique of determining a number of characters in column entries and then reducing a number of characters in those column entries if the entries exceed a specified width teaches” the limitation. Ex. 1005, 44; *see also id.* at 41–44 (citing Ex. 1007, Fig. 7, 4:66–67, 5:9–11, 8:22–29, 8:42–65). We credit Dr. Greenspun’s testimony, as it is consistent with Maloney’s and Bertram’s teachings discussed above.

We disagree with Patent Owner’s argument that the combination of Maloney and Bertram does not teach this limitation because the limitation “relies on a ‘determination of the number of characters in an entry.’” PO Resp. 51 (citing Ex. 2017 ¶ 28), 54–55 (citing Ex. 2017 ¶ 135). This

argument is predicated on Maloney and Bertram not teaching “determining a number of characters,” which is contrary to our findings. *See supra* Section IV(C)(5).

Based on the disclosures from Maloney and Bertram, and Dr. Greenspun’s testimony, we find that the combination of Maloney and Bertram teaches “if the number of characters included in each entry exceeds a specified amount of characters, displaying a portion of each entry in the selected database field, wherein a number of characters displayed in each portion is less than or equal to the specified amount of characters.”

*7. if the number of characters does not exceed*

Claim 1 also recites “*if the number of characters included in each entry does not exceed the specified amount, displaying each entry in its entirety.*” Ex. 1001, 24:65–67 (emphasis added to the condition). This limitation also is a conditional step. *See supra* Section III(C)(2). As we discuss above, this step does not need to be shown in showing unpatentability if the alternative conditional step is shown. *See supra* Section III(C)(1). Nonetheless, we now address this limitation as it pertains to our discussion below of Patent Owner’s Motion to Amend.

We agree with Petitioner that the combination of Maloney and Bertram teaches this limitation. *See* Pet. 25–26. In particular, we find that Bertram teaches for each entry of a plurality of entries in a column, if the width (i.e., the number of characters) does not exceed the set width (i.e., a specified amount of characters), displaying the entry in its entirety (i.e., no abbreviating). Ex. 1007, 6:24–54, 7:25–32, 8:22–65. As discussed above, Maloney teaches retrieving records (i.e., the entries in the selected database fields) for display from a database. Ex. 1006, 18:23–43, Fig. 20.

In addition, Dr. Greenspun testified that “*Maloney’s* display of entries for a selected database field in view of *Bertram’s* technique of determining a number of characters in column entries and then not reducing a number of characters in those column entries teaches if the entries do not exceed a specified width teaches” this latter conditional step. Ex. 1005, 46; *see also id.* at 44–46 (citing Ex. 1007, Fig. 7, 8:22–29, 8:58–65). We credit Dr. Greenspun’s testimony, as it is consistent with Maloney’s and Bertram’s teachings discussed above.

We disagree with Patent Owner’s argument that the combination of Maloney and Bertram does not teach this limitation because the limitation “relies on a ‘determination of the number of characters in an entry.’” PO Resp. 51 (citing Ex. 2017 ¶ 28), 54–55 (citing Ex. 2017 ¶ 135). This argument is predicated on Maloney and Bertram not teaching “determining a number of characters,” which is contrary to our findings. *See supra* Section IV(C)(5).

Based on the disclosures from Maloney and Bertram, and Dr. Greenspun’s testimony, we find that the combination of Maloney and Bertram teaches “if the number of characters included in each entry does not exceed the specified amount, displaying each entry in its entirety.”

#### 8. *Combining Maloney and Bertram*

We find that Petitioner has demonstrated by a preponderance of the evidence that one of ordinary skill in the art would have found it obvious to combine Maloney’s and Bertram’s teachings so as to render claim 1 obvious. More specifically, we find that Petitioner has demonstrated that one of ordinary skill in the art would have found it obvious to incorporate Bertram’s teaching of determining the number of characters in entries,

reducing the number of characters in the entries if the number exceeds a set width, and displaying either the entries in their entirety or in reduced form, into Maloney's database teachings to truncate text in each of the entries of the selected database fields while preserving readability.

We agree with Petitioner and find that Bertram provides express rationale to combine its techniques with systems such as those taught in Maloney. In particular, Bertram teaches that its techniques can be used for "displaying a plurality of columns on a display screen" and "can display information in a format more easily viewed by a user." Ex. 1007, 2:58–60, 3:4–6. Notably, Bertram describes that its techniques are applicable to "entries containing text data," which would include the entries (e.g., Item name entries) shown in Maloney's Figure 20. *Id.* at 7:25–32. Moreover, Bertram clearly teaches its techniques can be applied to each of a plurality of entries in a column. *Id.* at 6:24–54.

We also find persuasive Dr. Greenspun's declaration testimony. Dr. Greenspun testified that one of ordinary skill in the art:

would have understood that a given piece of data in a record returned from a query may include a string too long to display . . . , and . . . would have understood that a user selecting more fields . . . may result in narrower columns, which may necessitate text shortening, as taught by *Bertram*.

Thus, [one of ordinary skill in the art] would have been motivated to apply *Bertram*'s technique to the displays of *Maloney* (e.g., headings and entries of the columns in scrolling table 52 of Figure 20) in order to ensure that the columns of data can fit within a display window and would be readable to a user, as suggested by *Bertram*.

Ex. 1005 ¶¶ 57–58. Dr. Greenspun's declaration testimony comports with the express description in *Bertram* that *Bertram*'s shortening techniques are

widely applicable, including to multiple entries and multiple columns of displayed data. *E.g.*, Ex. 1007, 6:24–54.

We also agree with Petitioner and find that “[i]mplementing *Bertram*’s technique to the interface of *Maloney* is also an application of a known technique (reducing a number of characters in column data) to a known method (a graphical user interface displaying data in columns) ready for improvement to yield predictable results by achieving the benefits of *Bertram*.” Pet. 17 (citing Ex. 1005 ¶¶ 56–58); *KSR*, 550 U.S. at 416 (“The combination of familiar elements according to known methods is likely to be obvious when it does no more than yield predictable results.”).

We disagree with Patent Owner’s argument that one of ordinary skill in the art would not have combined *Bertram* with *Maloney* because doing so would render critical features of *Maloney* inoperable. PO Resp. 46–49. Patent Owner’s argument is based on an “extreme”<sup>10</sup> example where the specified amount of characters is set to *three*. *Id.* Using this example, Patent Owner argues that one of ordinary skill in the art would have recognized that *Bertram* would reduce *Maloney*’s column headings, or table names, so much that a user “would not know which names to select to create a report,” i.e., the headings would be unrecognizable. *Id.* at 49 (citing Ex. 2017 ¶¶ 140–141); *see also id.* at 47–49 (quoting Ex. 2015, 134:22–137:16) (arguing that Dr. Greenspun admitted that for a three character width, “it

---

<sup>10</sup> In questioning Dr. Greenspun, Patent Owner asked, “[i]f ‘storenm’ is abbreviated according to *Bertram*’s method 162 - and let’s say you just *took it to the extreme* where the column width was such that only three characters could be displayed - what would that end up looking like?” Ex. 2015, 135:21–136:2 (emphasis added).

would be kind of a mess, because [column headings] . . . would end up rendering the same in the display”).

Rather than focusing on an extreme example, the relevant inquiry is whether the claimed subject matter would have been obvious to one of ordinary skill in the art in light of the combined teachings of Maloney and Bertram. *See In re Keller*, 642 F.2d 413, 425 (CCPA 1981); *see also KSR*, 550 U.S. at 420–21 (finding the skilled artisan would “be able to fit the teachings of multiple patents together like pieces of a puzzle” because the skilled artisan is “a person of ordinary creativity, not an automaton”). As we discuss above, we find that combining Bertram’s reducing techniques for displaying entries with Maloney’s database teachings would have been obvious to one of ordinary skill in the art. Notably, Bertram’s example sets the width limit so that “a user can still distinguish between information contained in different columns of the table 200.” *See Ex. 1007*, 9:17–18, Fig. 8 (showing “BytsR” and “BytsS,” as well as “Dsk1W” and “Dsk2W”). In addition, Patent Owner’s argument also is premised on adding Bertram’s teachings to abbreviate Maloney’s column headings (i.e., field names) or table names. PO Resp. 46–49. Petitioner, however, combines Bertram’s teachings with Maloney’s teachings to abbreviate column *entries*. *See Pet. 20–26*.

We find that Dr. Chu’s declaration testimony is entitled to little or no weight for the reasons discussed above, as it is inconsistent with the combined teachings of Maloney and Bertram as applied to claim 1. *See Ex. 2017 ¶¶ 138–142*. For example, Dr. Chu focuses on alterations to Maloney’s table names, despite the Petition’s focus on shortening entries. *Id.* ¶ 141. Dr. Chu also opines that “any alteration of the table names could



result in an improper reference back to the physical database and a corresponding erroneous form.” *Id.* In contrast, the abbreviations of Bertram’s example still can be distinguished by a user. *See* Ex. 1007, 9:17–18, Fig. 8.

Lastly, we agree with Patent Owner that “[w]hether the names were permanently altered or merely altered for display is not germane.” PO Sur-Reply 1. The challenged claims are directed to “displaying data” and “formatting data for display,” and do not require the storage of truncated data. Ex. 1001, 24:51, 25:3–4. Regardless, we note that Bertram teaches “obtaining the entry” before the abbreviation and truncation process, which at least suggests that the process does not replace the stored entry. *E.g.*, Ex. 1007, 6:24–37.

Accordingly, for the reasons discussed above, Petitioner provided “some articulated reasoning with some rational underpinning to support the legal conclusion of obviousness.” *See In re Kahn*, 441 F.3d 977, 988 (Fed. Cir. 2006) (citations omitted), *cited with approval in KSR*, 550 U.S. at 418.

#### 9. Summary for Claim 1

Accordingly, based on a review of the entire record, we find that Petitioner has demonstrated by a preponderance of the evidence that Maloney combined with Bertram teaches each of the limitations recited in claim 1, and that one of ordinary skill in the art would have found it obvious to combine these teachings so as to render claim 1 obvious.

*D. Dependent Claim 2*

Claim 2 depends from claim 1, and recites the additional step of “providing a key word search.” Ex. 1001, 25:1–2. We agree with Petitioner that Maloney teaches this limitation. *See* Pet. 27. Maloney “allows end users to access database information through an intuitive ‘point and click’ graphical interface with knowledge of SQL commands, keywords, or syntax being required.” Ex. 1006, 17:5–8.

In addition, we find persuasive Dr. Greenspun’s testimony that “*Maloney’s* point and click graphical user interface allowing access to a database using keywords teaches” this additional step. Ex. 1005, 46. In support of this testimony, Dr. Greenspun quotes Maloney:

As stated above, with the present invention, end users are capable of designing forms and reports through the use of a logical schema interface without knowledge of the physical database schema. The present invention allows end users to access database information through an intuitive “point and click” graphical interface with knowledge of SQL commands, keywords, or syntax being required. End users gain access to the data in a syntax independent of the physical database schema.

*Id.* at 46–47 (quoting Ex. 1006, 17:2–10) (emphasis omitted). This passage teaches that, using Maloney’s logical schemas, a user can design forms and reports “*without* knowledge of the physical database schema.” Ex. 1006, 17:2–5 (emphasis added). However, users can access database information through Maloney’s “‘point and click’ graphical interface *with* knowledge of SQL commands, keywords, or syntax being required.” *Id.* at 17:5–8 (emphasis added). This pair of sentences appears to teach that a user does not need to know the physical database schema, but still needs some

knowledge (i.e., “knowledge of SQL commands, keywords, or syntax”) to access database information. *Id.* at 17:2–8.

We are not persuaded by Patent Owner’s argument that one of ordinary skill in the art “would understand that ‘with’ is an error; it should be ‘without,’” in the above passage in light of Maloney’s entire disclosure. PO Resp. 56. Patent Owner points to the “Background of the Invention” section in Maloney where it states:

Several problems have been associated with conventional relational database management systems. In some prior approaches, end users mainly access data in the database through the use of a database query language, such as SQL. *The problem with these command driven interfaces* is that they require a certain amount of data processing expertise on the part of the end user.

*Id.* (quoting Ex. 1006, 1:52–58) (emphasis added). These passages, read together, speak to Maloney providing a “‘point and click’ graphical interface” in lieu of a “command driven interface.” *Compare* Ex. 1006, 17:5–8, *with id.* at 1:52–58. Simply put, there is an insufficient basis in the record to say “with” is in error.

Based on the disclosure from Maloney, and Dr. Greenspun’s testimony, we find that Maloney teaches “providing a key word search.”

### *E. Independent Claim 3*

#### *1. Limitations That Are Substantially the Same*

Independent claim 3’s preamble and non-conditional steps (i.e., “generating a list of data fields,” “receiving a first data field selection from the list of data fields,” and “determining a first quantity indicative of a number of characters in each entry of the selected data field”) are substantially the same as limitations in claim 1 and its preamble. *Compare*

Ex. 1001, 24:51, 24:54–59, *with id.* at 25:3–9. Petitioner relies on substantially the same evidence and arguments for these limitations and preamble in claim 3 as in claim 1. *Compare* Pet. 17–26, *with id.* at 27–32. Patent Owner does not separately argue that Maloney and Bertram fail to teach these limitations. PO Resp. 57.

Therefore, for the reasons discussed above for claim 1, we find that the Maloney teaches claim 3’s preamble and non-conditional steps. *See supra* Section IV(C)(1, 3–5).

## 2. *Conditional Step*

Claim 3 also recites:

*if the first quantity exceeds a specified limit, reducing a number of characters to be displayed for each entry from the selected data field, comprising:*

performing a truncation that reduces the number of characters to be displayed from the selected data fi[el]d,  
comparing the reduced number of characters to the specified limit, and

if the reduced number of characters exceeds the specified limit, repeating the truncation and comparing steps until the reduced number of characters to be displayed from the selected data field is less than or equal to the specified limits; and

displaying the reduced number of characters for each entry from the selected data field.

Ex. 1001, 25:10–24 (emphasis added to the condition). As we discuss above, this is a conditional step, which does not need to be shown in finding unpatentability. *See supra* Section III(C)(1). Nonetheless, we now address this limitation as it pertains to our discussion below of Patent Owner’s Motion to Amend.

We agree with Petitioner that the combination of Maloney and Bertram teaches this limitation. Pet. 32–40. As discussed above, Maloney

teaches retrieving records (i.e., the entries in the selected database fields) for display from a database. Ex. 1006, 18:23–43, Fig. 20. In addition, Bertram teaches that for each entry from the selected data field, if the entry’s width (i.e., number of characters) exceeds a set width (i.e., a specified limit), reducing the number of characters to be displayed for each entry of the selected column. *E.g.*, Ex. 1007, 6:24–54, 7:25–32, 8:22–65, Fig. 7.

More specifically, Bertram teaches abbreviating one or more entries of a column for display by removing characters until each of the entries’ width (i.e., number of characters) is equal to or less than a set width (i.e., a specified limit). *E.g.*, Ex. 1007, 6:24–37, 7:25–32. Figure 7 illustrates an example method for abbreviating entries, one at a time, for display in accordance with Bertram’s invention. *Id.* at 3:25–27, 6:24–37, 7:25–32, Fig. 7; *see also supra* Section IV(B) (Summary of Bertram).

This method starts with the last character of the entry and removes it, depending on character type (e.g., spaces, lower case vowels, or lower case consonants) and if the entry exceeds the set width, and continues with the previous character until the first character in the entry or the set width is reached. *Id.* at 7:55–8:57, Fig. 7. In other words, if an entry is too wide — width checked at step 182 — the entry is abbreviated, working right to left, by first removing spaces, then lower case vowels, and then lower case consonants, in successive passes (i.e., an iterative process), until the entry no longer exceeds the set width. *Id.* at 8:3–57, Fig. 7. If after the character types have been processed, and the entry still is too wide — width checked at step 194 — the entry “is truncated to the appropriate number of characters.” *Id.* at 8:58–65, Fig. 7.

We find that these teachings from Bertram teach claim 3's

(i) performing a truncation that reduces the number of characters to be displayed from the selected data field, (ii) comparing the reduced number of characters to the specified limit (i.e., set width), and (iii) if the reduced number of characters exceeds the specified limit, repeating the truncation and comparing steps until the reduced number of characters is less than or equal to the specified limits. *E.g.*, Ex. 1007, 3:25–27, 6:24–37, 7:25–32, 7:55–8:65, Fig. 7.

For example, if the set width is five characters and an entry is seven characters in length with two spaces at the end (e.g., “abcde ”), the example method would (i) cut off the rightmost space (i.e., cut off the end of a series of characters, which is truncation), (ii) compare the width of the reduced entry (“abcde”) to the set width (five characters), (iii) because ( $6 > 5$ ), repeat the truncation step by cutting off the remaining space from the entry (“abcde”), repeat the compare step ( $5 \text{ not } > 5$ ), and stop because the reduced number of characters is equal to the specified limit. *Id.* Other examples of repeated truncation for a set width of five (under Figure 7's rubric) include (i) “ABCDEae,” which would be truncated to “ABCDE,” (ii) “ABCddii,” which would be truncated to “ABCdd,” and (iii) “abcdgaei,” which would be truncated to “abcdg.” Bertram further teaches that each of the truncated entries is displayed. *E.g.*, *id.* at 6:24–37.

In addition, we credit Dr. Greenspun's testimony that these teachings from Bertram, combined with the relevant teachings from Maloney, teach this limitation, as the testimony is consistent with Maloney's and Bertram's teachings discussed above. *See* Ex. 1005, 57–67 (citing Ex. 1007, Figs. 2, 7, 8, 4:66–67, 5:9–11, 8:3–29, 8:42–9:8).

Based on the disclosures from Maloney and Bertram, and Dr. Greenspun's testimony, we find that the combination of Maloney and Bertram teaches this conditional step.

### *3. Combining Maloney and Bertram*

Petitioner relies on the same arguments and evidence from claim 1 for the rationale to combine Maloney and Bertram for claim 3. Pet. 39. Likewise, Patent Owner relies on the same arguments and evidence in arguing that it would not have been obvious to combine Maloney and Bertram. PO Resp. 57. For the reasons we provide above for claim 1, we find that Petitioner has demonstrated by a preponderance of the evidence that one of ordinary skill in the art would have found it obvious to combine Maloney's and Bertram's teachings to render claim 3 obvious. *See supra* Section IV(C)(8).

### *4. Summary for Claim 3*

Accordingly, based on a review of the entire record, we find that Petitioner has demonstrated by a preponderance of the evidence that Maloney combined with Bertram teaches each of the limitations recited in claim 3, and that one of ordinary skill in the art would have found it obvious to combine these teachings so as to render claim 3 obvious.

### *F. Dependent Claims 4, 7–9, and 13*

As discussed below, Petitioner accounts for all of the claim limitations required by claims 4, 7–9, and 13 in the specific arrangement required by the claims and provides a reason to combine the teachings of Maloney and Bertram. Pet. 40–45; *see also* Ex. 1005, 67–73. Having considered the entirety of the evidence before us, both for and against obviousness, we find that Petitioner has demonstrated by a preponderance of the evidence that

claims 4, 7–9, and 13 of the '423 patent would have been obvious to a person of ordinary skill in the art based on the combined teachings of Maloney and Bertram.

Claim 4 depends from claim 3 and recites “wherein the specified limit is fixed.” Ex. 1001, 25:25–26. Petitioner argues Bertram teaches the additional limitation via Bertram’s teaching that “the set width of the column headings (specified limit) is unchanged during the actions of Fig. 7 (is fixed).” Pet. 40 (citing Ex. 1007, Fig. 7; Ex. 1005, 67–68). Patent Owner does not separately argue the patentability of claim 4. PO Resp. 57. We are persuaded by Petitioner’s analysis and find Bertram teaches the additional limitation. *See, e.g.*, Ex. 1007, Fig. 7. Accordingly, based on a review of the entire record, we find that Petitioner has demonstrated by a preponderance of the evidence that claim 4 would have been obvious over the combined teachings of Maloney and Bertram.

Claim 7 depends from claim 3 and recites “wherein the specified limit is a user-defined limit.” Ex. 1001, 25:33–34. Petitioner argues Bertram teaches the additional limitation via Bertram’s teaching that “[t]he user enters the desired width of the column heading via step 52.” Pet. 41 (quoting Ex. 1007, 4:66–67) (emphases omitted); *see also id.* (citing Ex. 1005, 68–69). Patent Owner does not separately argue the patentability of claim 7. PO Resp. 57. We are persuaded by Petitioner’s analysis and find Bertram teaches the additional limitation. *See, e.g.*, Ex. 1007, 4:66–67. Accordingly, based on a review of the entire record, we find that Petitioner has demonstrated by a preponderance of the evidence that claim 7 would have been obvious over the combined teachings of Maloney and Bertram.



Claim 8 depends from claim 3 and recites “wherein a parameter is related to the number of characters to be displayed from the selected data field, and wherein the truncation comprises decrementing the parameter.” Ex. 1001, 25:35–38. Petitioner argues Bertram teaches the additional limitation. Pet. 41–43. More specifically, Petitioner argues that Bertram teaches a parameter (i.e., the width in steps 182 and 194), which is “related to the set width by the actions in steps 182, 194,” i.e., the “width . . . is compared to a set width and is reduced by the actions of Figure 7 to be equal to or less than the set width.” *Id.* at 41–42 (citing Ex. 1007, Fig. 7; Ex. 1005, 69–70). In addition, Petitioner argues that Bertram teaches “decrementing the width by one character with each pass through step 188 as the truncation is performed,” as shown in Figure 7. *Id.* at 42–43 (citing Ex. 1007, Fig. 7; Ex. 1005, 70–71). Patent Owner does not separately argue the patentability of claim 8. PO Resp. 57. We are persuaded by Petitioner’s analysis and find Bertram teaches the additional limitation. *See, e.g.*, Ex. 1007, Fig. 7; Ex. 1005, 69–71. Accordingly, based on a review of the entire record, we find that Petitioner has demonstrated by a preponderance of the evidence that claim 8 would have been obvious over the combined teachings of Maloney and Bertram.

Claim 9 depends from claim 8 and recites “wherein the parameter is decremented or incremented by a value of one.” Ex. 1001, 25:39–40. Petitioner argues Bertram teaches the additional limitation via Bertram’s teaching that “the width (the parameter) is decremented by one with each pass through step 188.” Pet. 44 (citing Ex. 1007, Fig. 7; Ex. 1005, 72). Patent Owner does not separately argue the patentability of claim 9. PO Resp. 57. We are persuaded by Petitioner’s analysis and find Bertram

teaches the additional limitation. *See, e.g.*, Ex. 1007, Fig. 7. Accordingly, based on a review of the entire record, we find that Petitioner has demonstrated by a preponderance of the evidence that claim 9 would have been obvious over the combined teachings of Maloney and Bertram.

Claim 13 depends from claim 3 and recites “receiving a first constraint, wherein the first constraint is related to a data element in a data field; and receiving one or more subsequent constraints, wherein search results are generated based on a combination of the first and the one or more subsequent constraints.” Ex. 1001, 25:39–40. Petitioner argues Maloney teaches “two example constraints—customer and sale dates.” Pet. 44 (citing Ex. 1006, 18:22–43, Fig. 20; Ex. 1005, 72–73). Petitioner argues that at least two constraints (e.g., customer and sales date) are used to search the database, and either is the first constraint while the other is the second constraint. *Id.* at 44–45 (citing Ex. 1005, 73); *see also id.* at 44 (citing Ex. 1006, 18:22–43, Fig. 20). Petitioner argues that “the search results in Figure 20 are generated based on the customer and sales date constraints.” *Id.* at 45 (citing Ex. 1005, 73); *see also id.* at 44 (citing Ex. 1006, 18:22–43, Fig. 20). Patent Owner does not separately argue the patentability of claim 13. PO Resp. 57. We are persuaded by Petitioner’s analysis and find Maloney teaches the additional limitations. *See, e.g.*, Ex. 1006, 18:22–43, Fig. 20; *see also* Ex. 1005, 72–73. Accordingly, based on a review of the entire record, we find that Petitioner has demonstrated by a preponderance of the evidence that claim 13 would have been obvious over the combined teachings of Maloney and Bertram.

We have considered the entirety of the evidence submitted by the parties, and determine that Petitioner has shown, by a preponderance of the

evidence, that claims 4, 7–9, and 13 of the '423 patent would have been obvious to one of ordinary skill in the art over the combined teachings of Maloney and Bertram.

V. OBVIOUSNESS OVER MALONEY, BERTRAM, AND KANEVSKY

Petitioner argues claims 5 and 6 of the '423 patent are unpatentable under 35 U.S.C. § 103(a) as being obvious over the combination of Maloney, Bertram, and Kanevsky. Pet. 4, 78–82; Pet. Reply 26–28. Patent Owner argues that one of ordinary skill in the art would not have combined Maloney, Bertram, and Kanevsky's relevant teachings. PO Resp. 67–69.

We have reviewed the parties' arguments and the evidence of record. For the reasons that follow, we determine that Petitioner has shown by a preponderance of the evidence that claims 5 and 6 would have been obvious over the combination of Maloney, Bertram, and Kanevsky.

A. *Summary of Kanevsky*

Kanevsky discloses displaying data on a computer screen or window. *See Ex. 1008*, [57], 1:6–11. Kanevsky recognizes, however, that computer screens and windows may vary in size. *E.g., id.* at [57], 1:60–65. To address this variance, Kanevsky teaches adapting the display of data to accommodate screens and windows of different sizes. *See id.* Kanevsky teaches that this adaption can be automatic, “employ[ing] variables that provide size of screen and/or window information associated with the visual display from which a call to a web site was initiated.” *Id.* at 2:2–5, 2:16–19. Kanevsky thus “permit[s] automatic display of the content of web pages in the most friendly manner for a user viewing this content from a screen or window of a certain size.” *Id.* at 2:2–5.

*B. Claim 5*

Claim 5 depends from claim 3, and further recites “wherein the specified limit is variable.” Ex. 1001, 25:27–28. We agree with Petitioner that the combination of Maloney, Bertram, and Kanevsky teaches the additional limitation of claim 5. Pet. 81. In particular, as we find above, Bertram’s “set width” teaches the claimed specified limit. *See* Section IV.E.2. And Kanevsky teaches an “adaptation strategy [that] employs variables that provide size of screen and/or window information associated with the visual display from which a call to a web site was initiated.” Ex. 1008, 2:16–19; *see also id.* at 1:56–2:19, 2:20–3:19, 6:53–7:56.

We also find persuasive Dr. Greenspun’s testimony that one of ordinary skill in the art “would have made *Bertram*’s specified limit variable in light of the teaching of Kanevsky to adapt to a variety of screen sizes.” Ex. 1005, 127.

Based on the disclosures from Bertram and Kanevsky, and Dr. Greenspun’s testimony, we find that the combination of Maloney, Bertram, and Kanevsky teaches “wherein the specified limit is variable.”

*C. Claim 6*

Claim 6 depends from claim 3, and recites “wherein each entry from the selected data field is displayed on a terminal, and wherein the specified limit is determined dynamically, based on a characteristic of the terminal.” Ex. 1001, 25:29–32. We agree with Petitioner that the combination of Maloney, Bertram, and Kanevsky teaches the additional limitation of claim 6. Pet. 81–82. In particular, Maloney teaches that the data (i.e., each entry from the selected data field) is displayed on a terminal. *E.g.*, Ex. 1006, 4:5–20; *see also* Ex. 1005, 128–29. Bertram’s “set width” teaches the claimed

specified limit. *See* Section IV.E.2. And Kanevsky teaches an “adaptation strategy [that] employs variables that provide size of screen and/or window information associated with the visual display from which a call to a web site was initiated.” Ex. 1008, 2:16–19; *see also id.* at 1:56–2:19, 2:20–3:19, 6:53–7:56.

Based on the disclosures from Maloney and Kanevsky, we find that the combination of Maloney, Bertram, and Kanevsky teaches “wherein each entry from the selected data field is displayed on a terminal, and wherein the specified limit is determined dynamically, based on a characteristic of the terminal.”

*D. Combining Maloney, Bertram, and Kanevsky*

We find that Petitioner has demonstrated by a preponderance of the evidence that one of ordinary skill in the art would have found it obvious to combine Maloney’s, Bertram’s, and Kanevsky’s teachings to render claims 5 and 6 obvious. More specifically, we find that Petitioner demonstrates that one of ordinary skill in the art would have found it obvious to incorporate Bertram’s teaching of determining the width of entries, reducing the number of characters in the entries if the number exceeds a set width, and displaying either the entries in their entirety or in reduced form, into Maloney’s database teachings to shorten text in each of the entries in Maloney’s columns while preserving readability. We also find that Petitioner demonstrates that one of ordinary skill in the art would have found it obvious to further incorporate Kanevsky’s teachings so that Maloney’s and Bertram’s display of data could be adapted to a given screen or window size to further increase readability.

As we discuss above, we find that one of ordinary skill in the art would have found it obvious to combine Maloney and Bertram’s teachings for displaying data. *See supra* Section IV(C)(8). Furthermore, Kanevsky teaches adapting, for a given screen or window size, the display of data to provide the data “in the most friendly manner for a user viewing this [data] from a screen or window of a certain size.” *E.g.*, Ex. 1008, [57], 2:16–19. We agree with Petitioner and find that, based on Kanevsky’s teachings, one of ordinary skill in the art “would have used *Kanevsky*’s teaching of adaptive data display sizes for different screens and windows and applied that to the combination of *Maloney* and *Bertram* by adjusting *Bertram*’s ‘set width.’” Pet. 79 (citing Ex. 1005 ¶ 73).

We also are persuaded by Dr. Greenspun’s testimony that one of ordinary skill in the art “would have understood that the set width of *Bertram* may be variable and set based on a size characteristic of a terminal by, e.g., using tables that contain display characteristics of terminals, as taught by *Kanevsky*.” Ex. 1005 ¶ 74. Dr. Greenspun’s declaration testimony comports with Kanevsky’s teachings that the data display can be varied for a wide variety of screens or windows and Bertram’s teachings for reducing the amount of horizontal screen space required. *E.g.*, Ex. 1007, 6:24–54; Ex. 1008, [57], 2:2–5.

We also agree with Petitioner and find that “combining the teachings of *Kanevsky* with *Maloney* and *Bertram* would produce predictable, operable results because it would have been no more than the combination of known elements according to known methods, as *Kanevsky* recites familiar components (*e.g.*, computing devices) and techniques (displaying information on those devices).” Pet. 80 (citing Ex. 1008, 1:56–6, 2:8–10;

Ex. 1005 ¶ 75); *see also KSR*, 550 U.S. at 416 (“The combination of familiar elements according to known methods is likely to be obvious when it does no more than yield predictable results.”).

We disagree with Patent Owner’s argument that one of ordinary skill in the art would not have found it obvious to combine Kanevsky’s teachings with the teachings of Maloney and Bertram. PO Resp. 67–68. In particular, we find that (i) Patent Owner incorrectly applies Kanevsky’s specific techniques (e.g., using Kanevsky’s semantic interpreter module and prioritizing sections for removal) to (ii) Patent Owner’s specific characterizations of Maloney (i.e., Maloney’s data displays represent unitary objects), in a manner akin to arguing that Kanevsky cannot be physically combined with Maloney. *Id.* (citing Ex. 1006, Figs. 18, 20; Ex. 2015, 134:–136:8). Such an argument is improper. *See In re Etter*, 756 F.2d 852, 859 (Fed. Cir. 1985) (en banc) (“*Etter*’s assertions that Azure cannot be incorporated in Ambrosio are basically irrelevant, the criterion being not whether the references could be physically combined but whether the claimed inventions are rendered obvious by the teachings of the prior art as a whole.”). We likewise find that Dr. Chu’s testimony supporting Patent Owner’s argument is entitled to little or no weight for the same reason. *See* Ex. 2017 ¶ 124.

Rather, Petitioner simply relies on Kanevsky’s teachings that available display space can vary, including based on the size of a given screen or window, and applies those teachings to Bertram’s set width. Pet. 79–80 (citing Ex. 1008, [57], 1:60–66, 2:2–5); Pet. Reply 26–27 (citing Ex. 1005 ¶¶ 73–74). Accordingly, we disagree with Patent Owner’s argument. *See Riverbed Tech., Inc. v. Realtime Data LLC*, Case IPR2016-

00978, slip op. at 18 (PTAB Oct. 30, 2017) (Paper 67) (finding an argument against a portion of prior art reference not relied upon by Petitioner as not being persuasive).

Accordingly, for the reasons discussed above, Petitioner provided “some articulated reasoning with some rational underpinning to support the legal conclusion of obviousness.” *Kahn*, 441 F.3d at 988.

VI. OBVIOUSNESS OVER EXCEL AND BERTRAM; AND EXCEL, BERTRAM, AND KANEVSKY

Petitioner contends that (i) claims 1–4, 7–9, and 13 are unpatentable based on the combination of Excel and Bertram, and (ii) claims 5 and 6 are unpatentable over the combination of Excel, Bertram, and Kanevsky. Pet. 45–78, 82–85. Thus, these grounds of unpatentability challenge claims we have already determined are unpatentable under the combinations of (i) Maloney and Bertram and (ii) Maloney, Bertram, and Kanevsky. Under the circumstances of this case, analyzing additional grounds challenging the same claims, which we have determined to be unpatentable, would not be an efficient use of the Board’s time and resources. *See* 35 U.S.C. § 318(a) (providing that the Board “shall issue a final written decision with respect to the patentability of any patent claim challenged by the petitioner and any new claim added” by amendment during the proceeding); Guidance on the Impact of SAS on AIA Trial Proceedings (Apr. 26, 2018)<sup>11</sup> (“[I]f the PTAB institutes a trial, the PTAB will institute on all challenges raised in the petition . . . . The final written decision will address, to the extent claims are still pending at the time of decision, all patent claims challenged by the

---

<sup>11</sup> Available at [www.uspto.gov/patents-application-process/patent-trial-and-appeal-board/trials/guidance-impact-sas-aia-trial](http://www.uspto.gov/patents-application-process/patent-trial-and-appeal-board/trials/guidance-impact-sas-aia-trial).



petitioner and all new claims added through the amendment process.”).

Accordingly, we do not reach Petitioner’s asserted grounds based on the combination of Excel and Bertram, or Excel, Bertram, and Kanevsky. *Cf. In re Gleave*, 560 F.3d 1331, 1338 (Fed. Cir. 2009) (not reaching other grounds of unpatentability after affirming the anticipation ground); *see also Beloit Corp. v. Valmet Oy*, 742 F.2d 1421, 1423 (Fed. Cir. 1984) (determining once a dispositive issue is decided, there is no need to decide other issues).

## VII. PATENT OWNER’S MOTION TO AMEND

As discussed above, Petitioner has demonstrated by a preponderance of the evidence that claims 1–9 and 13 of the ’423 patent are unpatentable. We therefore consider Patent Owner’s contingent Motion to Amend, which seeks to replace claims 1, 3, and 6 with claims 24, 25, and 27,<sup>12</sup> respectively. MTA 3–4.

In an *inter partes* review, amended claims are not added to a patent as of right but, rather, must be proposed as a part of a motion to amend. 35 U.S.C. § 316(d); *Lectrosonics, Inc. v. Zaxcom, Inc.*, Case IPR2018-01129, slip op. at 2 (PTAB Feb. 25, 2019) (Paper 15) (precedential). We must assess the patentability of the proposed, substitute claims “without placing the burden of persuasion on the patent owner.” *Aqua Prods., Inc. v. Matal*, 872 F.3d 1290, 1328 (Fed. Cir. 2017) (en banc). Rather, “[t]he

---

<sup>12</sup> We understand that Patent Owner seeks to have claim 6 replaced with claim 27 in light of our finding that claims 3 and 6 are unpatentable. MTA 3–4. We view Patent Owner’s heading for claim 27 as containing a typographical error. Claim App’x. 2. We also note that Patent Owner does not explain clearly how claim 6 could be found unpatentable without also finding claim 3 unpatentable. MTA 3–4.

petitioner bears the burden of proving that proposed amended claims are unpatentable.” *Sirona Dental Sys. GmbH v. Institut Straumann AG*, 892 F.3d 1349, 1357 (Fed. Cir. 2018); *see also Lectrosonics*, Paper 15, at 4. For the reasons explained below, considering the record before us, we determine that Petitioner has shown by a preponderance of the evidence that proposed substitute claims 24, 25, and 27 are unpatentable.

*A. Proposed Substitute Claims 24 and 25*

Patent Owner proposes replacing claim 1 with substitute claim 24, and replacing claim 3 with substitute claim 25. MTA 3–4. Substitute claims 24 and 25 are reproduced below, with underlining indicating added language, and with bracketing indicating deleted language, from the original claims.

24. A computer-implemented method for displaying data comprising:

determining a database schema for a database;

providing a list of database fields, wherein the list includes a descriptor indicating a data category;

receiving a search selection for a database field on the provided list of database fields;

determining a number of characters included in each entry in a plurality of entries in the selected database field; [and]

[if the number of characters included in each entry exceeds a specified amount of characters], truncating each entry having a number of characters determined to be greater than a specified number of characters and displaying a truncated portion of each entry in the selected database field, [wherein] the displayed truncated portion truncated to reduce a number of characters to be[displayed in each portion is] less than or equal to the specified number [amount] of characters; and

[if the number of characters included in each entry does not exceed the specified amount,] displaying each entry having a number of characters determined to be less than or equal to the specified number in its entirety.

Claim App'x. 1.

25. A computer-implemented method for formatting data for display, comprising:

generating a list of data fields;

receiving a first data field selection from the list of data fields;

determining a first [quantity indicative of a] number of characters in each entry in a plurality of entries of the selected data field;

[if the first quantity exceeds a specified limit,] performing an iterative process to reduce [reducing] a number of characters to be displayed for each entry from the selected data field that exceeds a specified limit on the number of characters to be displayed, comprising:

performing a truncation that reduces the number of characters to be displayed from the selected data field,

comparing the reduced number of characters to the specified limit, and

[if the reduced number of characters exceeds the specified limit,] repeating the truncation and comparing steps until the reduced number of characters to be displayed from the selected data field is less than or equal to the specified limit[s];  
and

displaying the reduced number of characters for each entry from the selected data field.

*Id.* at 1–2.

Patent Owner argues that substitute claim 24 “clarifies that a number of characters is determined for a plurality of database entries, that reduction of the number of characters occurs by truncation, and that none of the steps of the claim are to be considered conditional.” MTA 1 (emphasis omitted).

Patent Owner argues that substitute claim 25, likewise, “clarifies that a number of characters is determined for a plurality of database entries and that none of the steps are to be considered conditional; Claim 25 also further specifies that it is the actual number of characters determined, not a qua[n]ity indicative of such number.” *Id.* (emphasis omitted).

As discussed above, Patent Owner does not have the burden of persuasion with respect to the patentability of the substitute claims presented in its Motion to Amend. *See Aqua Prods.*, 872 F.3d at 1327. Petitioner argues that proposed amendments to the independent claims “are no more than obvious variations of the previously-recited limitations,” which Petitioner already showed were present in the prior art in its Petition. MTA Opp. 1–2. For example, Petitioner argues the Petition shows that “*Bertram* clearly contemplates determining a number of characters for a ‘plurality of entries.’” *Id.* at 9–10 (citing Pet. 22), 11 (citing Pet. 61–64). Petitioner also argues that the Petition shows that *Bertram* teaches “displaying a portion of each entry in the selected database field.” *Id.* at 10 (citing Pet. 23–25, 55–57). Petitioner also argues that the Petition shows that *Bertram* teaches that reducing a number of characters in column entries can occur by truncating the entries. *Id.* at 10 (citing Pet. 24–25, 34–37). Petitioner also argues that the Petition shows that *Bertram* teaches an “iterative process” for removing characters from each entry in a column of entries. *Id.* at 12 (citing Pet. 15). Patent Owner relies on its arguments in its Response as to the patentability of substitute claims 24 and 25. MTA 15–16; MTA Reply 6.

We agree with Petitioner and find that the Petition shows the subject matter of the proposed amendments to claims 1 and 3, as well as the

unchanged limitations.<sup>13</sup> For example, the Petition shows that the combination of Maloney and Bertram teaches (i) determining a number of characters for each entry in a plurality of entries (*see supra* Section IV(C)(5)), (ii) that the reduction of the number of characters for each entry in a plurality of entries can occur by truncation (*see supra* Section IV(E)(2)), (iii) the recited conditional steps (*see supra* Sections IV(C)(6–7) and IV(E)(2)), and (iv) an “iterative process” for removing characters from each entry in a column of entries (*see supra* Section IV(E)(2)).

Accordingly, based on a review of the entire record, we find that Petitioner has demonstrated by a preponderance of the evidence that Maloney combined with Bertram teaches each of the limitations recited in substitute claims 24 and 25, and that one of ordinary skill in the art would have found it obvious to combine these teachings so as to render substitute claims 24 and 25 obvious.

---

<sup>13</sup> In fact, Patent Owner acknowledged at the oral hearing that the proposed amendments to claims 1 and 3 only address the treatment of conditional limitations under *Schulhauser* and do not otherwise distinguish the claims from the combination of Maloney and Bertram. Tr. 47:4–11. Thus, because the combination of Maloney and Bertram teaches all the conditional limitations of claims 1 and 3, the proposed amendments do not distinguish the claims from that prior art.

*B. Proposed Substitute Claim 27<sup>14</sup>*

Patent Owner proposes replacing claim 6 with substitute claim 27. MTA 3–4. Substitute claim 27 is reproduced below, with underlining indicating added language, and with bracketing indicating deleted language, from the original claim.

27. The method of claim [3] 25, wherein [each entry] all entries from the selected data field [is] displayed on a single page of a terminal, and wherein the specified limit is determined dynamically, based on a characteristic of the terminal.

Claim App’x. 2.

Patent Owner argues that substitute claim 27 “provide[s] a further limitation that all entries are to be displayed on a single page of the terminal.” MTA 1. As discussed above, Patent Owner does not have the burden of persuasion with respect to the patentability of the substitute claims presented in its Motion to Amend. *See Aqua Prods.*, 872 F.3d at 1327.

Petitioner argues that, in addition to its previous showings in the Petition, Bertram shows that “all entries from the selected data field [are] displayed on a single page of a terminal.” MTA Opp. 13–14. More specifically, Petitioner argues that Bertram describes that, as a result of truncation, a previously unviewable column, referred to as column 80, “can be displayed to the system administrator without horizontal scrolling.” *Id.* (citing Ex. 1007, 5:9–24; Ex. 1013 ¶ 13). In other words, Bertram truncates the column headings so that all columns can be displayed on a single screen

---

<sup>14</sup> We do not reach proposed, substitute claim 26 as we find that claims 3 and 6 are unpatentable. MTA 3–4. Regardless, proposed, substitute claims 26 and 27 “are substantively identical,” according to Patent Owner. *Id.*

of a terminal, according to Petitioner. *Id.* Petitioner argues that Bertram thus “teaches the claim feature, as its techniques would result in displaying a given set of data ‘on a single page of a terminal.’” *Id.* at 14 (citing Ex. 1013 ¶ 13). Patent Owner does not provide separate arguments as to the patentability of substitute claim 27. MTA 16; MTA Reply 6–7.

We agree with Petitioner and find that Bertram teaches that all of the column entries from the selected data field are displayed on a single page of a terminal. Ex. 1007, 5:9–24. For example, we find Bertram teaches that a table is displayed after a conventional truncation method has been used to truncate each of the entries in each of the columns to be five characters in width, and thus, the last column can be displayed without horizontal scrolling. *Id.*

In addition, we find Dr. Greenspun’s testimony persuasive as it comports with the cited teachings from the prior art. *See* Ex. 1013 ¶ 13.

Dr. Greenspun testified:

[T]his claim limitation would be taught by *Maloney* and *Bertram* . . . if the underlying database were small in size. At least some tables would not contain enough data for a multiple screen display to be necessary in the first instance. As an example, when a database or a spreadsheet is initially populated with a small set of data, retrieval of some of that data would in many instances result in a small number of rows of data that would fit on a single page of a terminal as recited in the proposed claims.

Ex. 1013 ¶ 13.

Accordingly, based on a review of the entire record, we find that Petitioner has demonstrated by a preponderance of the evidence that the combination of *Maloney*, *Bertram*, and *Kanevsky* teaches each of the limitations recited in substitute claim 27, and that one of ordinary skill in the

art would have found it obvious to combine these teachings so as to render substitute claim 27 obvious.

*C. Conclusion on Motion Amend*

As explained above, Petitioner has shown by a preponderance of the evidence that the subject matter of substitute claims 24, 25, and 27 would be unpatentable. Accordingly, we deny Patent Owner's Motion to Amend.

VIII. MOTION TO EXCLUDE EVIDENCE

Patent Owner's Motion to Exclude Evidence seeks the exclusion of Exhibit 1013 (Declaration of Dr. Philip Greenspun) and Exhibit 1014 (U.S. Patent No. 6,452,597, Goldberg). Petitioner filed these exhibits with its Opposition to Patent Owner's Motion to Amend, and cited to them therein.

In particular, Patent Owner seeks to exclude these exhibits under Federal Rules of Evidence Rule 403, based on Petitioner's purported admission that "*Goldberg* provides no additional teachings over that provided in the initially-cited references." Mot. Ex. Ev. 1. As to Exhibit 1013, it includes expert testimony relating to Goldberg, according to Patent Owner. *Id.* at 2 (citing Ex. 1013 ¶ 14). "Patent Owner asserts that consideration of Exhibits 1013 and 1014 would unfairly prejudice Patent Owner, confuse the issues, produce undue delay, waste time of Patent Owner and the Panel, and needlessly present cumulative evidence." *Id.* at 1. Petitioner opposes Patent Owner's motion. *See generally* Opp. Ex. Ev.

In our findings above, we do not rely on Goldberg or the portions of Exhibit 1013 that relate to Goldberg. Rather, we deny Patent Owner's Motion to Amend based on prior art made of record with the Petition, without considering the specific objected to Goldberg evidence or the



portions of Exhibit 1013 that relate to Goldberg. Accordingly, we dismiss Patent Owner's Motion to Exclude Evidence.

IX. CONCLUSION

Based on the full record before us, we determine that Petitioner has demonstrated by a preponderance of the evidence that (i) claims 1–4, 7–9, and 13 are unpatentable under 35 U.S.C. § 103(a) as obvious over Maloney and Bertram; and (ii) claims 5 and 6 are unpatentable under 35 U.S.C. § 103(a) as obvious over Maloney, Bertram, and Kanevsky. We deny Patent Owner's Motion to Amend to replace claims 1, 3, and 6 with substitute claims 24–27. We dismiss Patent Owner's Motion to Exclude Evidence.

X. ORDER

Accordingly, it is:

ORDERED that claims 1–9 and 13 of U.S. Patent No. 7,302,423 B2 have been shown by a preponderance of the evidence to be unpatentable;

FURTHER ORDERED that Patent Owner's Motion to Amend is *denied*;

FURTHER ORDERED that Patent Owner's Motion to Exclude Evidence is *dismissed*; and

FURTHER ORDERED that, because this is a final written decision, parties to the proceedings seeking judicial review of the decision must comply with the notice and service requirements of 37 C.F.R. § 90.2.

IPR2018-00044  
Patent 7,302,423 B2

For PETITIONER:

David M. O'Dell  
David L. McCombs  
Thomas Kelton  
John Russell Emerson  
Scott Cunning  
HAYNES AND BOONE, LLP  
david.odell.ipr@haynesboone.com  
david.mcombs.ipr@haynesboone.com  
thomas.kelton.ipr@haynesboone.com  
russell.emerson.ipr@haynesboone.com  
scott.cunning.ipr@haynesboone.com

Jonathan Stroud  
Roshan Mansinghani  
UNIFIED PATENT INC.  
jonathan@unifiedpatents.com  
roshan@unifiedpatents.com

For PATENT OWNER:

John K. Harrop  
Dickinson Wright, PLLC  
harrop@vapatent.com